

OPEN ACCESS PRICING METHODOLOGIES IN ECONOMICALLY ADAPTED ELECTRIC TRANSMISSION SYSTEMS

Hugh Rudnick, Eliana Cura, Rodrigo Palma

Departamento de Ingeniería Eléctrica
Pontificia Universidad Católica de Chile
Casilla 306, Correo 22, Santiago, Chile

Abstract. Open access pricing methodologies are evaluated in a deregulated environment, as applied to an economically adapted electric transmission system over a ten year time horizon. A transmission planning methodology using a genetic algorithm is used to determine the adapted system and the required investment over the horizon. A production cost simulation algorithm is utilized to determine the operation of the hydroelectric system and the resultant short term marginal income. Different pricing methodologies to allocate the required supplement, as applied to the Chilean central interconnected electrical system, are evaluated: use of system, postage stamp and user benefit. The resultant payment allocations are assessed and their economic impact on participants is discussed.

Keywords: deregulation, transmission open access, transmission planning, transmission cost allocation, transmission regulation.

I INTRODUCTION

The pricing of transmission open access and associated ancillary services is receiving increasing attention worldwide. Several countries are deregulating their electric power sectors to allow for competition among generators and to create market conditions in the sector, that are seen as necessary conditions for increasing the efficiency of electric energy production and distribution, offering a lower price, higher quality and more secure product. A necessary condition for competition to take place is that of generators being able to reach consumers through the transmission network, which can be achieved through open access schemes.

Different approaches have been followed to cost and price open access in interconnected power systems [1,2,3]. Problems such as transmission costing and pricing, payment allocation, access policies, transmission rights, do not have clear cut answers that can be applied universally. The paper contributes to the analysis of different payment allocation schemes, as applied to an "economically adapted" transmission system, as defined in the new regulations of three South American countries.

II ECONOMICALLY ADAPTED TRANSMISSION SYSTEMS

Electric power system planning in a competitive economic environment is an emerging complex issue. With private investment and competition in generation, no centralized planning takes place and the expansion is dictated

by market considerations. The Bolivian, Chilean and Peruvian electric regulations have faced this issue through two novel ideas [4].

First, an indicative reference generation-transmission expansion plan is determined by the regulator every six months and used for regulating tariffs to small retail consumers. In practice, regulators have only provided indicative plans for generation investments, with only major transmission lines included, for the same reasons that planners worldwide have usually decoupled both planning problems.

Second, an economically adapted transmission system is determined by the regulator. The Chilean 1982 electricity law [5] provides a general definition: "an installation is economically adapted when it allows to produce a given quantity at the lowest cost". Penalty factors, based on an adapted transmission system, are calculated by the regulator and are used to spatially distribute spot prices to main buses, starting from the load center spot price. The Peruvian 1992 legislation [6] delimitates the definition by indicating that "an economically adapted system is that electrical system where there is an equilibrium between energy offer and demand, seeking for reduced costs and maintaining quality of service". The Peruvian regulator not only is responsible for determining the adapted transmission system, but restricts the transmission owner income based on that adapted system. The objective is to stimulate efficient investment, maintenance and operation. Finally, the Bolivian 1994 legislation [7] follows the Peruvian model.

The economic adaptation notion used in these three countries relates to concepts formulated by Electricité de France economists back in 1949. The economic interpretation of an adapted transmission system requires therefore to optimize transmission development over time. Dynamic planning methodologies are required for the optimization.

III TRANSMISSION PLANNING

Transmission planning is a large scale problem that is complicated by many factors. A dynamic planning methodology suitable for determining the economically adapted transmission system required in the described regulations is not commercially available. The authors have developed and successfully tested an heuristic dynamic methodology using genetic algorithms [8]. It starts from a previously determined indicative plan for generation. The economically adapted transmission system to determine is the

one that provides the transmission service at minimum cost. Minimum cost to determine considers both cost of transmission investment and losses and variable cost of generation. The objective function, evaluated over a time horizon T, is

$$Min F = \sum_{t=1}^T [C_{invest}^t + \sum_{i=1}^N (C_{gen}^i + C_{unserv}^i)]$$

where

- $t = 1, \dots, T$ time periods
- $i = 1, \dots, N$ buses
- C_{invest}^t transmission and transformation investment annuities
- C_{gen}^i annual variable cost of generation
- C_{unserv}^i annual cost of non served energy

Optimization is achieved by controlling transmission investment decisions. A methodology using genetic algorithms was used by the authors to solve the problem [8].

IV PRODUCTION COST SIMULATION

The economic evaluation of a transmission expansion plan involves both determining investment and operation costs. A production cost simulation computer program was specifically developed for this purpose [9]. Operation costs are obtained through a simulation of the generation-transmission system over the time horizon, assuming an optimal dispatch strategy. The simulation considers a given indicative generation investment plan, including thermal plants as well as run of river and reservoir hydro plants, each with maximum and minimum generations. Fuel costs for thermal plants are used, while the strategic value of stored water for each reservoir plant is incorporated, thus representing the necessary hydrothermal coordination. The hydrologic stochasticity is modeled through the consideration of equiprobable dry, medium and wet years. Maximum demand, load growth, load factor and cost of unserved energy are specified for each bus. Demand is modeled through the duration curve, divided in three steps of different widths. The optimal dispatches for each period (and each hydro year and each load level) provide operational costs and unserved energy costs (to obtain expected value of operation) as well as dual variable multipliers (to calculate sensitivities). Values are weighted in relation to their time duration.

V ECONOMICALLY ADAPTED CHILEAN TRANSMISSION SYSTEM

The determination of the economically adapted transmission system for the main Chilean power grid was made [8]. The system is characterized by its radial longitudinal structure (2000 km), with most of its generation installed capacity being hydro (75%) and located in the south of the network. Load is concentrated in the central region (70% of total load). Reservoirs with important storage capabilities are in the south, while the most efficient thermal generation is next to the load. The economic adaptation was searched in a ten year horizon, considering yearly stages. Initial maximum demand is 2530 MW, with a 6% load

growth rate and a 0.67 load factor. A discount rate of 10% is used, considering a useful life of 30 years for transmission equipment. A reduced model, that keeps the main generation, transmission and load features of the original Chilean system, is used to illustrate results. The reduced system models 8 buses and 10 possible line paths. Within the horizon, the model considers 6 thermal plants, 5 run of river hydraulic plants and one large reservoir plant. Four alternative investment schemes were considered for each path. The alternative schemes may combine three voltage levels (154, 220 and 500 kV) and single and double circuits. An initial expansion plan was proposed. New expansion plans were created from that proposed plan, incorporating changes randomly generated as well as changes determined from electric sensitivities. Aprox. 2500 plans were simulated, each simulation covering 90 economic dispatches, corresponding to 10 years, 3 load levels and 3 hydrological availability conditions. The genetic algorithm was successful in significantly improving the initial plan.

The best plan obtained was chosen as the resultant economically adapted transmission network (Fig. 1). The initial network at year zero considers lines installed in all paths, except for paths West1-East and North2-West2, that are available starting on years 4 and 8 respectively.

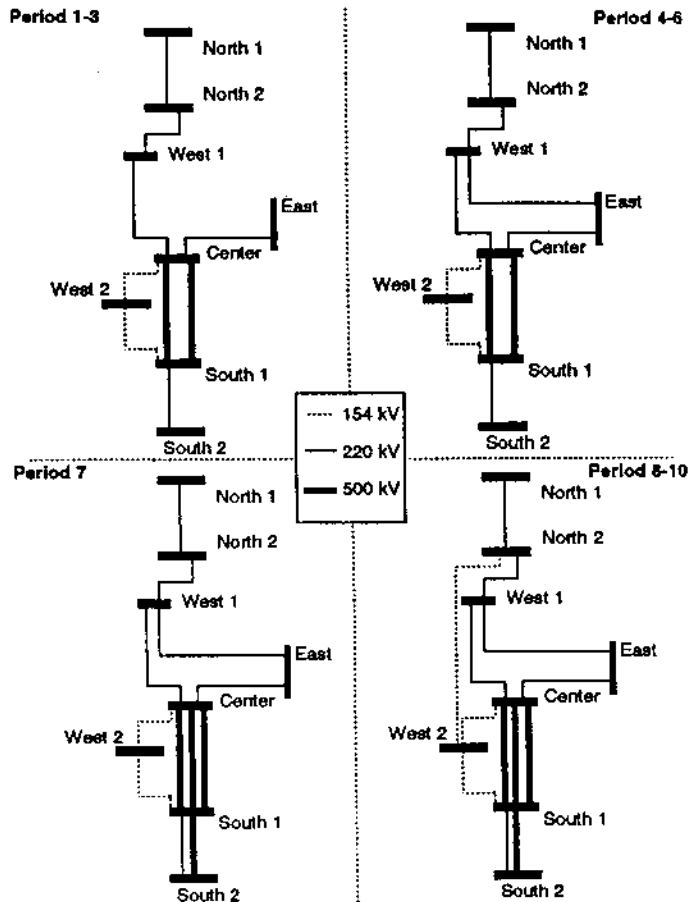

Fig. 1. Adapted transmission network expansion plan

VI TRANSMISSION PRICING METHODOLOGIES

Three pricing methodologies were evaluated for two different lines of the determined adapted transmission system for the ten year horizon. They all assume that replacement values are used for costing transmission lines; they further consider that a basic income, a marginal revenue, is obtained for paying transmission services as a result of geographical differences of spot prices in the different buses (both concepts coherent with the transmission pricing regulations of the three countries). They all assume that only generators pay for the main grid transmission. Grid transmission is understood as the high voltage meshed network that is shared by all generators. Radial transmission or subtransmission used by individual generators or consumers is left out.

The methodologies differ in the way they allocate the extra required income among generators (supplement toll). The three alternative supplement allocation methodologies evaluated are [3]:

- 1) Generalized Generation Distribution Factors, based on use of the system, which represents the impact of total generation change in total flow over each system line.
- 2) Proportional to average generation of each generator bus, for each year of the study
- 3) Proportional to the benefit that represents to each generator bus the existence of a system path between two buses.

Bolivia and Chile use the first methodology for payment allocation, while Perú uses the second one (it corresponds to a postage stamp method). The third alternative has been proposed in Argentina, but the first one is still in use there.

Simulations of the system were made, considering optimal generation dispatches over the ten year period, with the generation plan and demand growth used when determining the adapted transmission system. Maximum load and a medium hydrological condition were considered. Even though the generation-transmission system has been optimized, line congestion conditions appear at different stages (the optimization finds it preferable to additional investment). Transmission payments were to be allocated globally to each generation bus, irrespective of the presence of different plant owners in each bus.

Two transmission paths were chosen for comparing the methodologies:

- i) Center - West2, a 154 kV path, with transmission installations that remain unchanged along the 10 years.
- ii) Center - South1, a 500 kV path where there is an increase in the number of circuits on the seventh year.

Given economies of scale in transmission (lines, transformers and compensation equipment), the lumpiness of standardized transmission voltages and the transmission

security requirements (redundancies determined by n-1 criteria), the marginal revenue is not sufficient to cover the required transmission remuneration. This condition changes when transmission congestion takes place.

Figures 2 and 3 illustrate the collected marginal revenue along the 10 year horizon as well as the resultant allocated payments for each generation bus for the two paths along the horizon, when using the three indicated alternatives. The distribution of payments changes considerably over the study horizon, providing different variable economic signals.

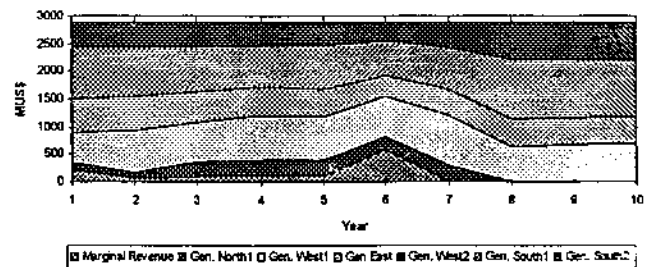

Generalized Generation Distribution Factors Method

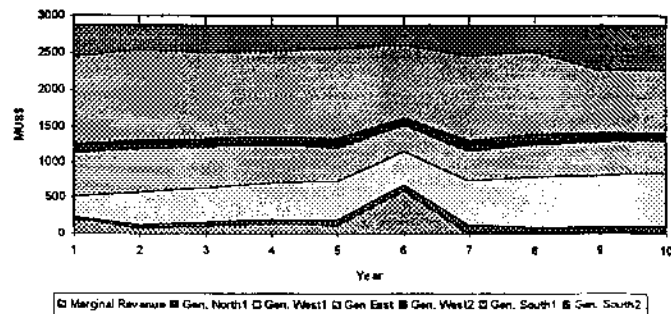

Average Generation Method

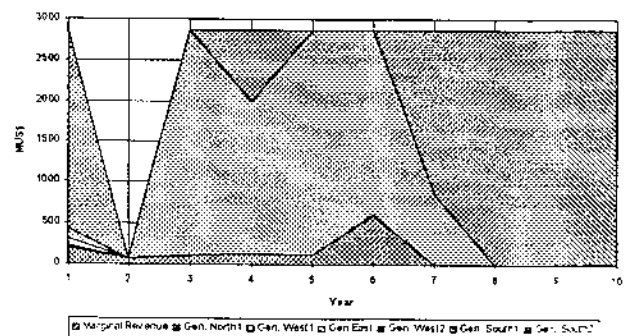

Benefit Method

Fig. 2. Marginal revenue and allocated generator payments for Center-West2 path

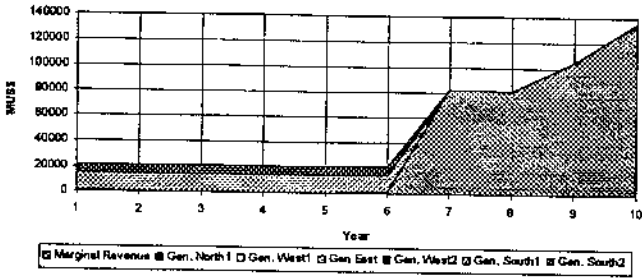

Generalized Generation Distribution Factors Method

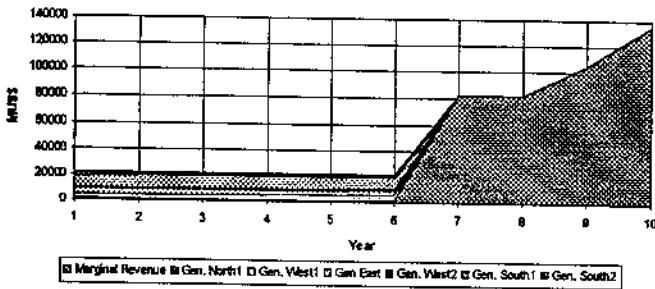

Average Generation Method

Fig. 3. Marginal revenue and allocated generator payments for Center-South1 path

The payments cover the supplement needed to complete the insufficient marginal revenue. That is why for path Center - South1 there is no additional toll for years seven to ten where congestion appears and the marginal revenue exceeds the required annual revenue. On the other hand, for Center - West2 path there is a negative marginal revenue (considered no revenue), for the same years. In this case, the total annual revenue required is allocated among the generation buses.

To further illustrate the impact of the methodologies, the resultant required payments to two generation buses are compared: bus South1, which has hydro generation and bus East, with thermal generation. Figures 4 and 5 illustrate the allocated payments.

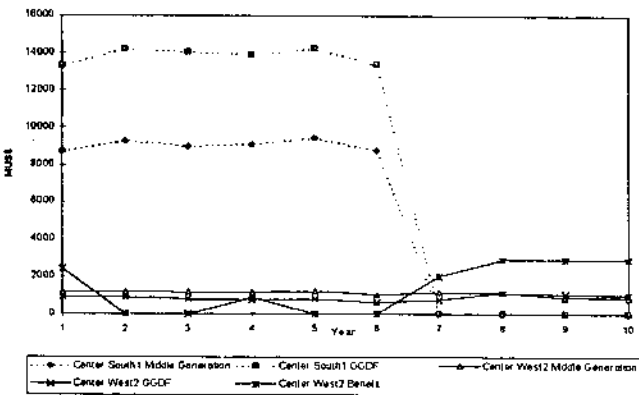

Fig. 4. Allocated payments for generation bus South1

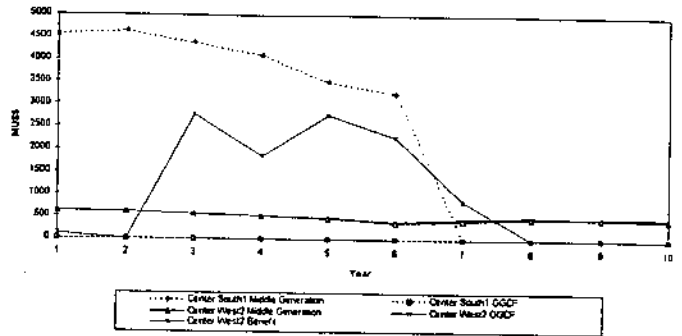

Fig. 5. Allocated payments for generation bus East

VII EVALUATION OF ALLOCATION METHODOLOGIES

A brief comparison of the three methodologies is made based on the previous results.

i) Payment of Center- South1 path

For bus South 1, there is a significant difference between the allocated payments based on methodologies 1 and 2.

Payments based on Generalized Generation Distribution Factors would encourage generation plant investment near to the load center. With this methodology, bus East is released from paying for the use of Center-South1 path.

If methodology 2 is utilized, bus East needs to contribute to the required annual revenue. This methodology would not encourage generators to search for the most economic location, but would give more importance to optimizing the size and the starting period of the new plant.

ii) Payment of Center- West2 path

Methodologies 1 and 2 allocate similar payments for generation bus South1. Both methodologies are stable along the study horizon and would promote the establishment of long term contracts between the generation plant owners and the transmission owners.

Considering the third methodology, the allocated payments are unstable along the study horizon. This could create difficulties in the signing of long term transmission contracts, limiting incentives for investment by the transmission path owner along that path.

For bus East, methodologies 1 and 2 allocate similar payments and reduced in comparison with those resulting of applying methodology 3.

Center - West2 path has no marginal revenue for years seven to ten, which creates an additional risk for the

transmission owner if it depends on supplement contracts, particularly if an unstable benefit methodology is used.

Methodology 2 is the simplest to apply of the three, the most complex being number 3. It is difficult to evaluate the benefits to participants with every modification of the structure of the system. Besides, for a longitudinal system like the Chilean one, there are lines that can not be taken out to determine who they benefit; the system can not operate as a whole without them.

The length of the transmission contracts is a relevant question when assessing which methodology is better. Methodologies 1 and 2, as applied to the Chilean system, fit better for longer periods of contract standing, without need for intermediate re evaluation. Clearly, the instability of payment allocation of methodology 3 would be incoherent with an extended contract.

VIII ACKNOWLEDGMENTS

The authors acknowledge the financial assistance from Fondecyt. The support of ENDESA to the research and development activities of the Universidad Católica Electric Power Group is deeply appreciated. The authors' views are their own and not necessarily those of any other individual or organization.

IX REFERENCES

- [1] Rudnick, H. "International experience in transmission open access: Argentinean, Chilean and Peruvian perspectives", IEEE Power Engineering Review, December 1994, Vol. 14, Nº12, pp 11-12.
- [2] Pérez-Arriaga, I., Rudnick, H., Stadlín, W. "International power system transmission open access experience". IEEE Transactions on Power Systems, Vol. 10, Nº1, February 1995, pp. 554-561.

- [3] Rudnick, H., Palma, R., Fernández, J. "Marginal pricing and supplement cost allocation in transmission open access". IEEE Transactions on Power Systems, Vol. 10, Nº2, May 1995, pp. 1125-1132.
- [4] Rudnick, H., "Planning in a deregulated environment in developing countries: the cases of Bolivia, Chile and Perú", Panel on Improvements in Power Generation and Transmission Systems for Developing Countries, IEEE Power Engineering Society 1996 Winter Meeting, Baltimore, MD, January 1996.
- [5] Electricity Services Law Decrees, Chile, 1982, 1985 and 1990
- [6] Electricity Services Law Decrees, Perú, 1992 and 1993
- [7] Electricity Services Law Decrees, Bolivia, 1994
- [8] Rudnick, H., Palma, R., Cura, E., Silva, C., "Economically adapted transmission systems in open access schemes- Application of genetic algorithms", IEEE/PES 1995 Summer Meeting, Portland, Oregon, July 23-27, pp. 1-8.
- [9] Palma, R., Rudnick, H., Lira, H. "Penalty factor calculations for marginal pricing of transmission systems in a hydroelectrical system". Proceedings of the International Symposium on Electric Power Engineering, Stockholm, Sweden, June 18-22, 1995, pp. 704-709.

Hugh Rudnick was born in Santiago, Chile. He graduated as a Civil Electrical Engineer from University of Chile and received his M.Sc. and Ph.D. degrees from Victoria University of Manchester. He is a Professor of Electrical Engineering at Catholic University of Chile. His research activities focus on power system economic operation and planning. He has been a consultant with utilities and regulators in Argentina, Bolivia, Chile and Colombia.

Ellana Cura was born in Santiago, Chile. She received her B.Sc. in Electrical Engineering from Catholic University of Chile. She works at TRANSELEC, the main transmission company in the Chilean central interconnected system. Her research interests include transmission pricing methodologies and economic operation of power systems.

Rodrigo Palma was born in Antofagasta, Chile. He received his B.Sc. and M.Sc. in Electrical Engineering from Catholic University of Chile. He is working for his Ph.D. degree at the University of Dortmund, Germany. His research interests include electric sector deregulation, economic operation of power systems and nonlinear optimization.