

Battery Powered Electric Car, Using Photovoltaic Cells Assistance

Juan Dixon, Alberto Zúñiga, Angel Abusleme and Daniel Soto

Abstract

One of the major problems for the massive applicability of Electric Vehicles (EVs) is the scarce capacity of conventional electrical energy storage systems. Although this constraint has been overcome in many cases using advanced technologies such as fuel cells and high-capacity batteries, it is still difficult to develop an economically viable and socially acceptable EV for massive use. In this context, solar energy is not a practical solution for satisfying this lack of energy. However, if a particular situation is considered, in which a small-sized, high-efficiency EV operates at low duty cycles in a sunny, predictable environment, solar power can become a solution for reducing transport costs.

Keywords: solar energy, battery charge, photovoltaic.

1 Introduction

Although range is an important issue to consider when evaluating a vehicle, it is also a relative figure. Several studies during the last years show that the average commuter travel distance in U.S. cities has been and keeps around 10 miles. In this situation, commuter-oriented EVs can be developed with a reduced load of batteries, and therefore, a reduced power plant. In these conditions, solar energy can be managed in order to produce a palpable contribution to the EV energy source. This particular situation considers a light, small-sized, high-efficiency EV operating at low duty cycles in a sunny, predictable environment. In this case, solar power can become a real solution for reducing commuter transport costs and incrementing range. Energy collected by solar cells located on the vehicle's roof, as shown in figure 1, can be an important part of the total energy required by the vehicle when moving or when charging its batteries under all other circumstances.

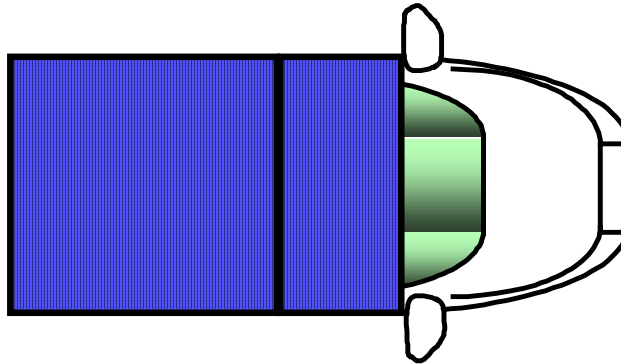

Figure 1: Vehicle top view

As this approach does not need additional expensive infrastructure, such as a solar net or stationary solar generators, it can only be useful under certain, controlled conditions, and these conditions must be determined in order to evaluate whether this solution yields real improvements in the vehicle's performance. This paper deals with the features of this approach. In first place, some basic operation and design characteristics for a small EV are exposed. Then, a mathematical model is presented to evaluate cell performance, followed by the analysis of practical data obtained from a photovoltaic assisted EV. Finally the impact environmental conditions have on photovoltaic systems is studied and potential of solar power applied on a small efficient EV is discussed.

One of the objectives of this work is to evaluate a low-cost, environmental-friendly mean of transportation. Both features are well achieved if lead-acid batteries are used, because they are relatively cheap and almost fully recyclable. For this reason, deep discharge, sealed lead-acid batteries will be considered. These batteries present a specific energy of 35 Wh/kg for a 3-hour discharge rate (figure pertinent for EV calculations). If the vehicle carries 100 kg of batteries, the total energy is 3.5 kWh. However, in order to avoid permanent damage, batteries cannot be fully discharged. Considering an 80% deep of discharge (DOD), the total energy available in the batteries is roughly 2.8 kWh.

The concept of commuter-oriented EV represents a particular case of a standard EV. Although commuter-oriented EVs should be more restricted than standard EVs, important improvements in performance could be reached when operated under certain conditions. In order to maximize the vehicle performance, these conditions must be optimal. With this aim, a sunny, predictable environment with high insolation levels over the year must be chosen. To agree with this, the region must be preferably a desert near equator with low probabilities of clouds. Located in Chile, Atacama Desert is the most arid place in the world. It almost never rains there, and skies are clear during 98% of the year. Its location (latitude 22° – 24° South) ensures long days during the entire year. Although high temperatures reduce solar cells performance, high insolation levels compensate this negative effect.

Also important in the success of small solar EVs is the use of highly efficient energy transfer systems. The Figure 2 shows the implemented system, which is able to transfer the energy from solar panels to battery with efficiencies between 95 % and 99%.

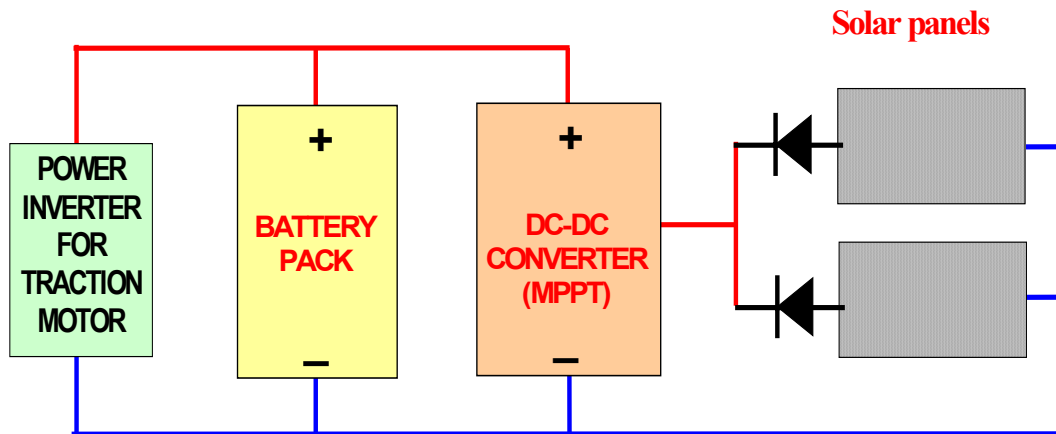

Figure 2: Solar energy transfer system.

To measure the improvement in performance of an EV, six solar panels of one square meter each were mounted on the roof of a conventional battery powered electric vehicle, which is shown in figure 3. The solar panels were built at the Department of Electrical Engineering, Pontificia Universidad Católica de Chile, using MAIN1530 RWE Schott Solar Cells [1] (10x15cm² with 15.5% conversion efficiency)



Figure 3: EV with 6 Solar Panels Installed on the Roof.

Because this vehicle is too big and heavy for the main purposes of this work, the increase in range of the vehicle will be carefully measured. This increase in range will take in account the climate of each particular day to see the improvement of efficiency related with the daily weather conditions.

2 Solar Cell Model

For the description of the electrical behavior of a solar cell during generating operation, the two diode model is commonly used [2]. This model, which is shown in figure 4, consists of two diodes and a resistance in parallel with the photocurrent source along with a resistance in series with the system mentioned

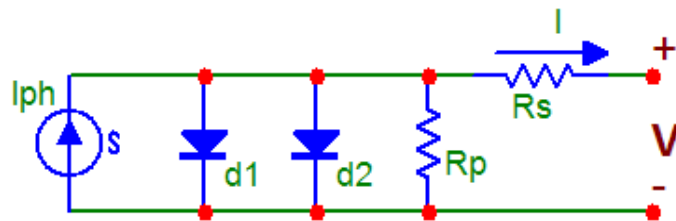

Figure 4: Equivalent Circuit of a Solar Cell

This circuit can be represented in mathematical terms using the exponential diode equation and Kirchhoff's Law [3].

$$I = I_{ph} - I_{S_1} \left(e^{\frac{q \cdot (V + I \cdot R_S)}{n_1 \cdot k \cdot T}} - 1 \right) - I_{S_2} \left(e^{\frac{q \cdot (V + I \cdot R_S)}{n_2 \cdot k \cdot T}} - 1 \right) - \frac{V + I \cdot R_S}{R_p} \quad (1)$$

The equation shows the dependence of the current on temperature; however the efficiency of the solar cell also involves irradiation. The following equations extend the dependence of the solar cells on temperature and show how irradiation (S in %) affects its performance [3].

$$I_{ph} = S \cdot I_{ph_Max} \quad (2)$$

$$I_{ph}(T) = I_{ph}|_{T=298^\circ K} \cdot \left(1 + (T - 298) \cdot (5 \cdot 10^{-4}) \right) \quad (3)$$

$$I_{S_2} = K_2 \cdot T^2 e^{-\frac{E_g}{k \cdot T}} \quad (4)$$

$$I_{S_1} = K_1 \cdot T^3 e^{-\frac{E_g}{k \cdot T}} \quad (5)$$

3 Simulation of Solar Cell

In order to obtain the solar cell characteristic curves from this model, each value of current I for a given voltage V must be computed individually. As equation (1) is implicit, numerical methods must be used to solve it. Due to its simplicity and fast rate of convergence Newton-Raphson's method was chosen. Using MATLAB to solve the equation, it was possible to generate a wide range of curves simulating different temperature and irradiation conditions.

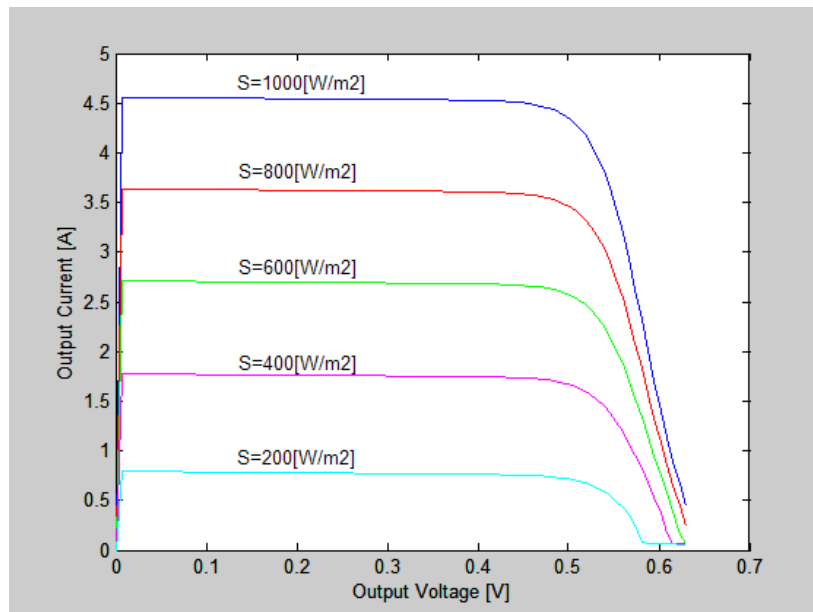

Figure 5: Irradiation Curves for T= 25°C

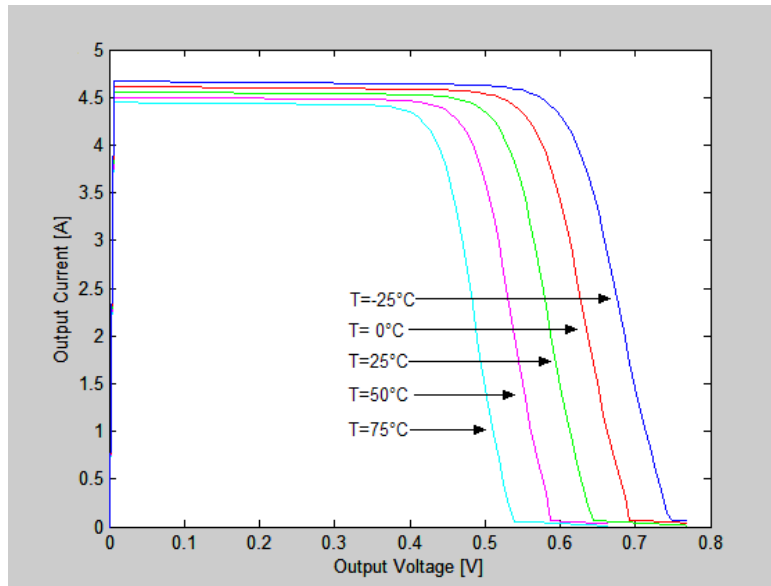

Figure 6: Temperature Curves for $S=1000 \text{ [W/m}^2\text{]}$

4 Solar Panel and MPPT

Using the cells simulated above, 6 solar panels were built, consisting on 50 cells in series each, the total surface covered by cells reaches $4.5 \text{ [m}^2\text{]}$. All panels working together can generate in ideal conditions (AM 1.5 G) a total power output of 678 [W] . According to design restrictions two columns of three panels in series were connected in parallel. This configuration delivers an average output current of 9 [A] with a nominal voltage of 75 [V] . Using the design restraint mentioned and the mathematical model, it's possible to obtain the power characteristic curve for each column in different temperature and irradiation conditions.

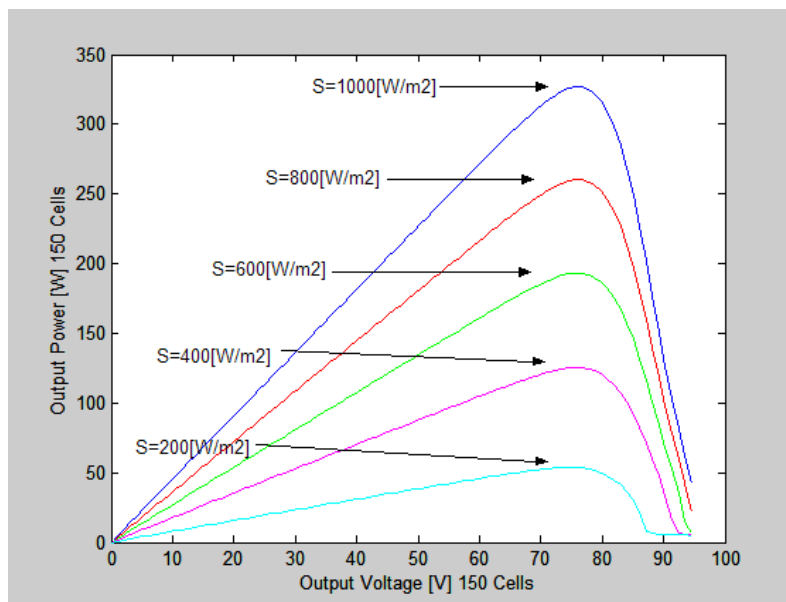

Fig. 7 Irradiation Power Curve for $T= 25^\circ\text{C}$

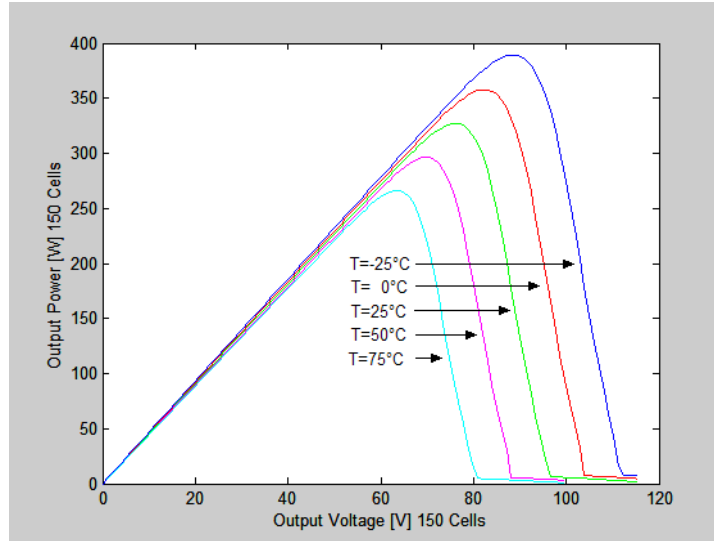

Fig. 8 Temperature Power Curve for $S=1000 \text{ [W/m}^2\text{]}$

The curves show the great impact both variables (T & S) have on the performance of the photovoltaic system. Reductions of irradiation in the order of 20% diminish the power output in approximately 30%, however temperature has not such an impact because a 25°C increase implies just a 10% power loss. Maximum power is obtained from the panels using an MPPT. An MPPT (Maximum Power Point Tracker) is a DC-DC converter that forces photovoltaic systems to operate at the precise voltage at which the peak value of power is obtained. When these gadgets are used to charge batteries, they can improve the charging performance in more than 20% [6]. For this reason a high performance MPPT was installed between the solar panels and the batteries.

5 Tests Results

The vehicle was tested in three different scenarios to evaluate its performance under different environmental conditions. The first one consisted on measurements with the vehicle parked on a normal parking lot during 90 min. which is a standard shopping time. The second one was similar because measurements were taken with the car parked in the same place, but for 8 straight hours, in this way a normal working day is simulated and the vehicle is exposed to a variable irradiation condition. The third test simulated a normal job-run, where the increase in autonomy was carefully measured.

In the first scenario tested, the solar panels showed an excessive operating temperature, where some cells exceeded 58°C , which would imply a reduction in the output power. During the test, the average output power was near 400 [W] with an average insolation of $990 \text{ [W/m}^2\text{]}$, which means that the panel efficiency was reduced to 9% mainly due to the increase in temperature and solar ray reflection. In this period of time the batteries received a total energy of 0.61 [kWh] which is enough to move the vehicle some 1.7 miles. According to U.S. statistics the average run is close to 10 miles (20 miles both ways), these would mean the solar panels can increase range in at least 8.5%. If the panels should have given full power, the total accumulated energy could have reached 0.93 [kWh], enough to move the vehicle 2.55 miles (12.9% increase in range)

The vehicle was tested in the city of Santiago de Chile, where the solar insolation during the month of November and December between 9:30 and 17:30 is around 6.7 [kWh/m²] [7]. During the tests in the second scenario, the photovoltaic system was able to generate 2.9 [kWh] out of the 30 [kWh] available, which means that the panels are operating with an efficiency around 10% (during the 8 hour of exposure). However this value is just a daily average, because the efficiency varies during the day as the next figure shows.

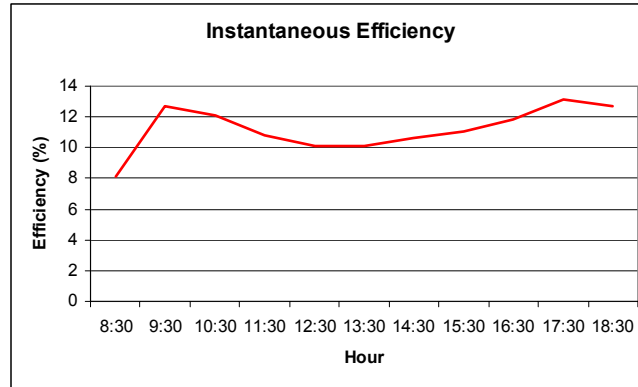

Fig. 9 Instantaneous Cells Efficiency

In the colder hours of the day the efficiency is better than in the hotter more insolated hours, showing the negative impact high temperatures have on the performance of the solar cells. Nevertheless the energy generated by the solar arrays can not be neglected, because it is enough to move the vehicle for more than 8 miles. This distance is almost the same as half of a normal 20 mile (both ways) run in the US, which means that 40% of the total energy can be self generated, reducing energy costs in the same amount. The days chosen for these tests were very similar and the charging curves obtained had similar slopes and minimum differences between one day and another. All of this shows that the operating characteristic is predictable and depends only on the weather conditions. However, using the two diode model the predictability can be taken to any weather condition. During a normal day the peak insolation point is near the solar zenith which happens around 1 p.m. At this point the energy flow from the panels to the batteries is at its peak, as shown in the following graph. From 11:00 am the energy flow tends to stay near 130 [Wh] every 20 minutes until 4:00 pm, showing that this flow stays near the cell saturation point neglecting the insolation level which varies considerably in between the mentioned hours.

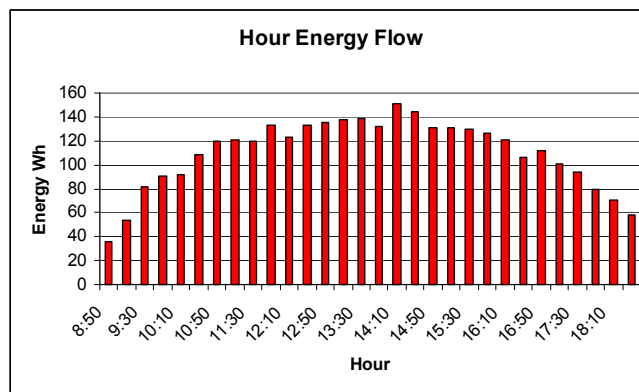

Fig. 10 Hourly Energy Flow

The tests carried out during the third scenario consisted on running the vehicle through the streets simulating a normal job run of 13 miles. In this condition the air flowing around the solar panels improve heat dissipation, so an increment in power is expected. Each test lasted one hour, and during this time the power output was near 555 [W], meaning that the better heat dissipation increased power and energy accumulation by 39%. As well as evaluating the efficiency obtained, the energy accumulation level starting the test with the batteries full and half charged was also measured. When the tests started with the batteries half charged the energy accumulation level increased 3.2%, which means that comparing to the static tests the energy level was greater in 43%. When the batteries are fully charged its impedance is greater than when it is half charged, then there are fewer losses during the charging process which explains why the energy accumulation level is greater with discharged batteries. The improvement in performance increases range significantly, which gives 1.73 miles in the case of full charged batteries and 1.82 miles with the batteries half charged. During these tests the solar cells functioned with efficiencies close to 12.5%, which is very good taking into account the poor heat dissipation level the solar panels have and solar reflection caused by the protective acrylic (6-10%).

The photovoltaic system was connected to the batteries through the MPPT to improve the energy flow. During all the tests performed, the MPPT efficiency was also measured. This device lifted the photovoltaic voltage (75 [V]) up to the 150 [V] of the batteries with a near 99% (practical) energy conversion. It also protects the cells from reverse currents from the batteries to the solar panels in shaded periods (night and underground parking lots) which would polarize in reverse form the solar cells destroying them immediately. It also forced the solar panels to work at its peak power point (according to the environmental conditions), which increases the photovoltaic performance. During the tests in the third scenario it could be seen that the power from the solar panels was slightly less with the batteries half charged that fully charged. Nevertheless the energy accumulated was greater during the half charged tests, demonstrating that the MPPT sensed this condition and forced the solar panels to give more current lowering the voltage (less power) and increasing the Ah storage. Taking these into account the use of this kind of gadgets is highly recommended for photovoltaic systems.

6 Environmental Conditions

Through this work the heat dissipation has been said to be the most important factor in the low performance of the solar cells. The wind passing around the solar panels during the tests performed in the third scenario showed that good heat dissipation can improve cell performance in nearly 40%. The temperatures shown above are averages of individual cell temperature, where some reached values over 58°C. When cells are overheated they tend to increase their internal impedance until they are fully saturated and current may not flow through them. This is the case of this project, due to the great number of cells connected in series, when one of them overheats (near saturation point) the whole system current is limited to the current this cell is able to hold, lowering the systems power output. In part this phenomenon explains the low output power obtained. However, it can't be denied that a better heat dissipation would have helped. However favorable environmental conditions increase the heat transfer rate improving heat dissipation and cell performance. From the results obtained during the tests, we could appreciate that performance was increased from 4% to 10% in the presence of favorable weather conditions, plenty of sun, low temperatures, light wind and high humidity.

7 Contribution of Solar Power to Small EV

In this section of the paper, a rough exercise oriented to the design of a small-size electric vehicle is shown. The exercise is based on energy availability and performance criteria. The objective is to compare its theoretical performance with and without the contribution of solar energy.

7.1 General vehicle parameters

Due to the scarce energy provided during a day by solar power, it is necessary to maximize the vehicle efficiency. In order to do that, the vehicle considered in this section should be small, aerodynamic, lightweight, and relatively low in acceleration and maximum speed. For this purpose, a two-person vehicle with a small trunk will be considered.

Most small-sized, high efficiency electric vehicles are very light. For example, Twike has a mass of 220-250 kg, including batteries [8]. Since it is difficult, risky and expensive to design and build a practical car with a lesser mass, it will be considered a 330-kg vehicle, without batteries. In practical electric vehicles, lead-acid batteries have a mass of at least 30% of the entire vehicle mass [9]. This rule can be applied on small-sized vehicles too. In this case, considering 100 kg of batteries, the total vehicle mass should be around 430 kg. If two 75-kg persons were also in the vehicle, the total mass would be around 580 kg.

The vehicle should be able to move in a 20% slope at a speed of 6.2 Mi/h with two persons on board, and reach a maximum speed of 46.5 Mi/h in plains. Considering 92% efficiency in the mechanical transmission mechanism, drag and the rolling resistance the power needed to move the car following the criterion mentioned is around 7 kW (nominal) [10].

Using previous figures, it is possible to determine an equation [10] for the vehicle expected range R in a flat, concrete freeway as a function of the speed, aerodynamic drag (F_d), rolling resistance (F_r) and battery capacity. The following equation does not consider the contribution of the solar batteries to the vehicle's energy:

$$R = \eta \cdot \frac{E_{batt}}{F_r + F_d} \quad (6)$$

The value of η can be obtained as the product of the efficiency of each component batteries, converters, motor and transmission system. Although efficiency depends on usage conditions, it is possible to set this value around 75%. Fig. 11 shows the EV range as a function of the speed, considering the parameters determined in this section.

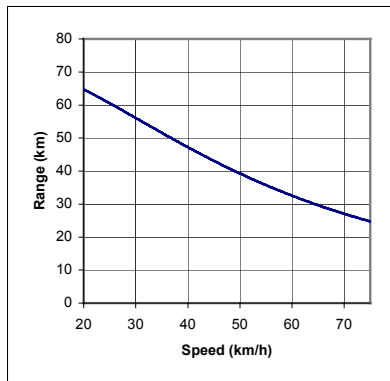

Fig. 11 Range as a function of speed in a small EV

As shown in the previous figure, the theoretical range is high enough for a commuter-oriented vehicle, since it considers short trips and long periods for recharging.

7.2 Contribution of solar energy to a small-size EV

The energy required by the EV to operate depends mainly on its speed. For low or medium speeds, the EV could be able to operate for relatively long distances with low energy requirements, due to its size and efficient design. This makes it possible for solar energy to do a real contribution to the energy available for the vehicle, improving range and reducing operation costs. In this section, basic calculations of the contribution of solar energy to a small-size electric vehicle are presented and discussed.

For a better performance, the vehicle should have a main solar panel on the roof and a secondary, telescopic panel under the main panel. When circulating, only the main solar panel will generate power; when parked, the telescopic panel should be deployed over the windshield using a rail system, collecting more solar energy.

If the mechanical design is adequate and the panels are set in a platform over the roof, its surface could be 1.82 m² (1.3 m width and 1.4 m length), leaving enough space for a significant windshield. The telescopic panel could be half the length of the main panel and the same width, obtaining a surface of 0.91 m². With both panels deployed, the vehicle would have a combined collecting surface of 2.73 m² (Fig. 1)

Using the practical data obtained in scenario 2, it is possible to estimate the amount of energy collected by the photovoltaic system (roof deployed) on a low insolation day in Calama, North of Chile ($I_H = 4$ kWh/m²). Neglecting the charge losses (supposing slow charge), the total energy collected (W_R) by the roof panel is:

$$W_R = \eta \cdot I_H \cdot A = 0.10 \cdot 4 \cdot 2.73 = 1.1 \text{ kWh} \quad (7)$$

This amount of energy is only a little more than one third of the available battery bank capacity. If the EV is parked and with the telescopic panel deployed during $\frac{3}{4}$ of the sunny hours, the total energy collected by the panels in one day of low insolation would be around 0.825 kWh, which barely represents a 29% the entire battery bank effective capacity. In high insolation days (7.8 kWh/m²/day), this figure can be doubled. In the best conditions, for an EV that leaves home early in the morning and arrives late at night, the total range can be increased in at least 70% considering that solar panels work more efficiently with the car in motion. Although cost reduction is minimal, the most important conclusion is that the vehicle travels with its own portable solar generator that, when deployed, is able to provide the EV with an important amount of energy whenever and wherever is required.

The figures shown above can be seriously increased if a good heat transfer system is included to the photovoltaic panels, figures up to 40% can be accomplished. However with the system as it is, the autonomy of a small EV can be increased in almost 60%, which is enough to justify the use of this kind of technology.

8 Solar Power Potential

In order to maximize the vehicle's performance, a sunny, predictable environment with high insolation levels over the year should be chosen. To agree with this, the region must be preferably a desert near equator with low probabilities of clouds. Located in Chile, Atacama Desert is the most arid place in the world. It almost never rains there, and skies are clear during 98% of the year. Found in this region

is the city of Calama which is suitable for the operation of photovoltaic assisted vehicles due to its small building and lack of trees, preventing shade. Table 1 shows the Calama's and Santiago's insolation [5] level during a 10 year average (kWh/m²/day):

Santiago	Jan	Feb	Mar	Apr	May	Jun	Jul	Aug	Sep	Oct	Nov	Dec	Annual Average
10 Year Average	6.54	5.66	4.99	3.71	2.63	2.19	2.46	3.35	4.24	5.19	5.92	6.70	4.46
Calama	Jan	Feb	Mar	Apr	May	Jun	Jul	Aug	Sep	Oct	Nov	Dec	Annual Average
10 Year Average	7.23	6.41	5.85	5.00	4.24	3.76	3.98	4.69	5.73	6.57	6.95	7.32	5.64

Table 1 Monthly Insolation Level

From the table it can be seen that in Calama the solar insolation is 26% greater than in Santiago, where the vehicle was tested. So the figures obtained previously on Chapter 5 may be increased in a similar proportion if the vehicle was to be tested in Calama. The table also shows that insolation level is steadier in this city than in Santiago, so a better performance is expected from the photovoltaic system. As mentioned before, the table shows a 10 year average for the insolation level; however today readings shows that these figures have increased in 18% due to the advance in the Ozone Layer Hole.

9 Conclusions

This work has showed that photovoltaic technology can be implemented to assist conventional and small size EV. The increment in the autonomy of both vehicles is good enough to justify its use. In long static charging conditions the energy generated by the solar cells cannot be neglected and is extremely useful to increase autonomy or reduce energy costs. However in these circumstances special attention has to be taken to the heat dissipation from the cells, because it tends to limit performance significantly. The increment in autonomy depends on the energy use of the vehicle, small, light EV will find autonomy increased considerable, however heavy vehicles will find slight to none improvements. Apart from solar insolation (which we don't control), heat accumulation is the most harmful variable to solar panel performance, diminishing it in more than 40% when one single cell exceeds 60°C. Environmental conditions plays an important role in heat transfer, good conditions favour heat dissipation while deficient conditions help to diminish performance. As well as heat, transparency is very important to improve cell operations. In this project, a 95% transparent acrylic was used to protect the cells from dust and other agents. The problem was that the system reduced its maximum efficiency from 15% to 14.2%. To model cell behaviour under different temperature and insolation conditions, the two diode model is extremely useful and trust worthy.

10 References

- [1] MAIN1530 RWE Schott Solar Cell Datasheet, 2003
- [2] V. Quasching and R. Hanitsch, "Numerical Simulation of Photovoltaic Generators with Shaded Cells" 30th Universities Power Engineering Conference, Greenwich, Sept. 5-7, 1995, pp. 583-586.
- [3] Hannes Knopf, "Analysis, Simulation And Evaluation Of Maximum Power Point Tracking (MPPT) Methods For A Solar Powered Vehicle", Portland State University, 1999.

- [4] Photovoltaic Energy Systems web page,
<http://emsolar.ee.tu-berlin.de/lehre/english/pv1/>
- [5] NASA Surface Meteorology and Solar Energy Data Set for Atacama Desert, Surface Meteorology and Solar Energy Data web page: <http://eosweb.larc.nasa.gov/sse/>
- [6] Soto, Daniel: “*Aumento del Rendimiento en un Vehículo Eléctrico, utilizando Celdas Fotovoltaicas*”. Electrical Engineer Tesis Work, 2002
- [7] Information about weather conditions from Dirección Meteorológica de Chile
- [8] TWIKE Operator’s Manual, <http://www.vmunoz.addr.com/twike/twikeem1.htm>
- [9] Bob Brant: *Build your own Electric Vehicle*, Tab Books, 1994
- [10] Abusleme, Angel, Dixon, Juan and Soto, Daniel. “*Improved Performance of a Battery Powered Electric Car, Using Photovoltaic Cells*”, IEEE Bologna Power Tech Conference, June 23-26, 2003, Bologna, Italy, on CD ROM.

11 Acknowledgments

The Authors want to thank Project Fondecyt N° 1020982 for the support given to this work

Authors



Juan Dixon, Department of Electrical Engineering, Pontificia Universidad Católica de Chile, Vicuña Mackenna 4860, Santiago, Chile, fax 56-2-552-2563, phone 56-2-354-4278, e-mail: jdixon@ing.puc.cl. He got the Ph.D. degree from McGill University, Montreal, Canada, in 1988. From 1977 to 1979 he was with the National Railways Company (Ferrocarriles del Estado). Since 1979 he is Professor at Pontificia Universidad Católica de Chile. His main research interests are electric vehicles, active power compensation, multilevel inverters and high power rectifiers



Alberto Zúñiga, Department of Electrical Engineering, Pontificia Universidad Católica de Chile, Vicuña Mackenna 4860, Santiago, Chile, fax 56-2-552-2563, phone 56-2-354-4278, e-mail



Angel Abusleme, Department of Electrical Engineering, Pontificia Universidad Católica de Chile, Vicuña Mackenna 4860, Santiago, Chile, fax 56-2-552-2563, phone 56-2-354-4278, e-mail: abusleme@stanford.edu. He received the electrical engineering degree and the M.Sc. degree in automatic control, both from the Catholic University of Chile, Santiago, Chile, in 2000. Since 2001 he has been an instructor at the Department of Electrical Engineering, Pontificia Universidad Católica de Chile. His main research interests are unmanned air vehicles, mobile robotics, solar energy and electro-dynamic suspension systems. He actually is doing is Ph.D. at Stanford University.

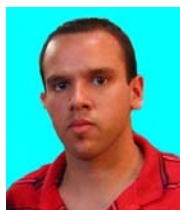

Daniel Soto received its Professional Degree of Civil Electrical Engineer in October of 2002. Presently, he is with AES-Gener, an Electric Generation Company, e-mail: daniel.soto@aes.com.