

Regenerative Braking for an Electric Vehicle Using Ultracapacitors and a Buck-Boost Converter

Juan W. Dixon, Micah Ortúzar and Eduardo Wiechmann*

Department of Electrical Engineering

Catholic University of Chile

Casilla 306, Correo 22

Santiago, Chile

Phone 56-2-686-4281

Fax 56-2-552-2563

e-mail: jdixon@ing.puc.cl

*University of Concepción

Abstract

An ultracapacitor bank control system for an Electric Vehicle has been simulated. The purpose of this device is to allow higher accelerations and decelerations of the vehicle with minimal loss of energy, and minimal degradation of the main battery pack. The system uses an IGBT Buck-Boost converter, which is connected to the ultracapacitor bank at the Boost side, and to the main battery at the Buck side. The control of the system measures the battery voltage, the battery state-of-charge, the car speed, the instantaneous currents in both the terminals (load and ultracapacitor), and the actual voltage of the ultracapacitor. This last indication allows to know the amount of energy stored in the ultracapacitor. A microcomputer control manipulates all the variables and generates the PWM switching pattern of the IGBTs. When the car runs at high speeds, the control keeps the capacitor discharged. If the car is not running, the capacitor bank remains charged at full voltage. Medium speeds keep the ultracapacitors at medium voltages, to allow future accelerations or decelerations. The battery voltage is an indication of the car instantaneous situation. When the vehicle is accelerating, the battery voltage goes down, which is an indication for the control to take energy from the ultracapacitor. In the opposite situation (regenerative braking), the battery voltage goes up, and then the control needs to activate the Buck converter to store the kinetic energy of the vehicle inside the ultracapacitor. The measurement of the currents in both sides allows to keep the current levels inside maximum ratings. The battery state-of-charge is used to change the voltage level of the ultracapacitor at particular values. If the battery is fully charged, the voltage level of the capacitors is kept at lower levels than when the battery is partially discharged. The converter also has an IGBT controlled power resistor, which allows to drop energy when in some extreme situations cannot be accepted neither for the ultracapacitors nor for the battery pack. The car that will be used for future implementation of this experiment is a Chevrolet LUV truck, similar in shape and size to a Chevrolet S-10. This vehicle was already converted to an electric car at the Catholic University of Chile.

Introduction

Ultracapacitors are a new technology that allows to store 20 times more energy than conventional electrolytic capacitors. Despite this important advance in energy storage, they are still far from being compared with electrochemical batteries. Even Lead-acid batteries can store at least ten times more energy than ultracapacitors. However, they present a lot better performance in specific power than any battery, and can be charged and discharged thousand of times without performance deterioration. These very good characteristics can be used in combination with normal electrochemical batteries, to improve the transient performance of an electric vehicle, and to increase the useful life of the batteries. Fast and sudden battery discharge during acceleration, or fast charge during regenerative braking can be avoided

with the help of ultracapacitors. Besides, ultracapacitors allow regenerative braking even with the batteries fully charged.

In this paper, an auxiliary ultracapacitor bank, using a Buck-Boost converter, has been simulated. The ultracapacitor has a capacity of 7 Farads, a nominal voltage of 300 Vdc, and a maximum voltage of 360 Vdc. It comprises 144 units in series, each one with 1,000 Farads, and 2.5 volts dc nominal (2,7 volts maximum). The maximum current is 400 amp, and the weight of the capacitor bank is 45 kg. The total weight of the equipment is estimated in 70 kg.

The System Proposed

The Figure 1 shows a diagram of the ultracapacitor system proposed. The power circuit has two main components: the Buck-Boost converter using IGBT's, and the ultracapacitor bank. The equipment is connected in parallel to the main battery, which has 26 batteries in series (312 Vdc nominal). The capacitor voltage is allowed to discharge until one third of its maximum voltage (around 120 Vdc), allowing to store an amount of 112 Wh of useful energy. This apparently poor amount of energy allows to have more than 40 kW of power during 10 seconds, which is more than enough time for a good acceleration (or deceleration) without detriment in the battery life. The nominal power of the traction motor is 32 kW, and the peak power is 53 kW. During acceleration, the IGBT **T1** is commutated, transferring energy from the capacitor to the main battery. During regenerative braking, the IGBT **T2** is operated, moving energy in the opposite direction. Because of the topology of the Buck-Boost converter, the ultracapacitor never reaches voltages higher than the battery pack (self-protection).

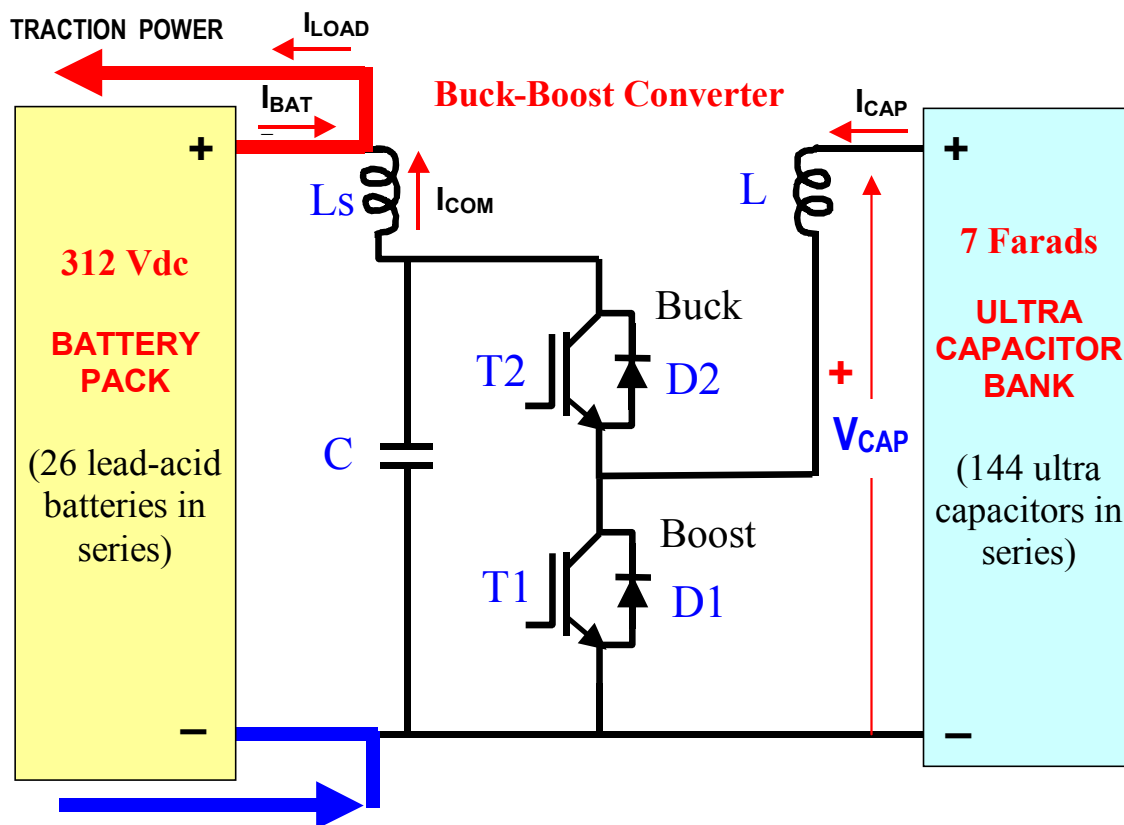

Figure 1
Ultracapacitor System

During Boost operation (acceleration), **T1** is switched on and off at a controlled duty cycle, to transfer the required amount of energy from the capacitor to the battery pack. When **T1** is ON, energy is taken from the capacitor, and stored in the inductor **L**. When **T1** is switched OFF, the energy stored in **L** is transferred into **C**, through **D2**, and then into the battery pack. The inductor **Ls** has the duty to soft the current pulses going to the battery pack.

During Buck operation, the converter introduces energy from the battery to the ultracapacitor. That operation is accomplished with a controlled PWM (Pulse Width Modulation) operation on **T2**. When **T2** is switched ON, the energy goes from the battery pack to the ultracapacitor, and **L** stores part of this energy. When **T2** is switched OFF, the remaining energy stored in **L** is transferred inside the ultracapacitor.

To do all the duties correctly, a good control strategy is required. The control strategy strongly depends on the size of the ultracapacitor. With a large capacity, the vehicle can run taking an almost constant battery current (the average current). Under these conditions, the capacitor gives all the positive and negative variations around this average current, and its voltage can indicate when is required to increase or decrease the average current given by the battery pack. However, this solution is costly because ultracapacitors are quite expensive right now. This reason forces to install an ultracapacitor as small as possible, but large enough to avoid battery voltages too low or too high, and battery currents (negative or positive) too high. Under these economical reasons, many variables need to be measured, each one with a different priority.

Control Strategy

Considering the high cost of the ultracapacitors, the total capacity in Farads has to be minimized. Then, a more complicated control strategy is required, because the energy stored is in this case limited. Every variable, such as instantaneous battery voltage, battery state of charge, instantaneous battery current, ultracapacitor initial conditions, capacitor current, and so, need to be sensed. The speed of the vehicle also needs to be taken in account because when the vehicle is going to start, all the capacitor energy will be required. By contrast, when the vehicle run at high speeds (more than 80 km/h), the ultracapacitors need to be empty, to be able to receive the energy coming from a sudden emergency stop. At medium speeds, the ultracapacitor should have in-between charge inside.

The state of charge has to be considered because full charged batteries do not accept any current, and hence, under this condition, the ultracapacitor has to be discharged (that means no more than 15-20 % of its full capacity). Only if the car goes to a total detention, some amount of energy could be required. By contrast, if the battery state of charge is poor, the ultracapacitor should keep an amount of energy higher than under normal conditions. The state of charge is estimated by time integration of the battery current (positive or negative). The system also recognizes a fully charged battery when its voltage goes up rapidly under a regenerative braking condition.

As the energy stored in the ultracapacitor is proportional to V_{CAP}^2 , this voltage gives a good indication of its remained charge. The capacitor voltage is being controlled by the IGBT PWM strategy applied to the **Buck-Boost Converter**, through the interaction of the other aforementioned variables, such as the vehicle speed, and the state of charge of the battery.

The measurement of the instantaneous battery voltage, and the sign of the load current (positive or negative), discriminates when the converter works under Boost or under Buck mode. If the battery voltage goes up rapidly, the controller activates the Buck operation, and a given amount of energy is transferred to the ultracapacitor. This situation happens when the vehicle is running and the brake is activated. Under this condition, the previous state of the overall system should have kept the ultracapacitor voltage at low levels. By contrast, the Boost operation will be activated when the battery

voltage goes down (acceleration), and when the vehicle is going to move, or accelerating from low speeds (positive current from the batteries). Under these conditions, and if the battery is not fully charged, the ultracapacitors should be at high levels of stored energy.

All the operation described above, has to be controlled by a microprocessor, which discriminates and takes the appropriate decisions for each particular situation. The best way to give each variable a right significance, is by using a combined control. This combined control has two levels: a *Primary Control*, and a *Secondary Control*. The *Primary Control* establishes the **CURRENT REFERENCE** (I_{REF}) to be given to the ultracapacitor for each operation condition, and the *Secondary Control* generates the PWM signals for the **Buck-Boost Converter**. The Figure 2 shows the *Primary Control*, and the Figure 3 shows the *Secondary Control*.

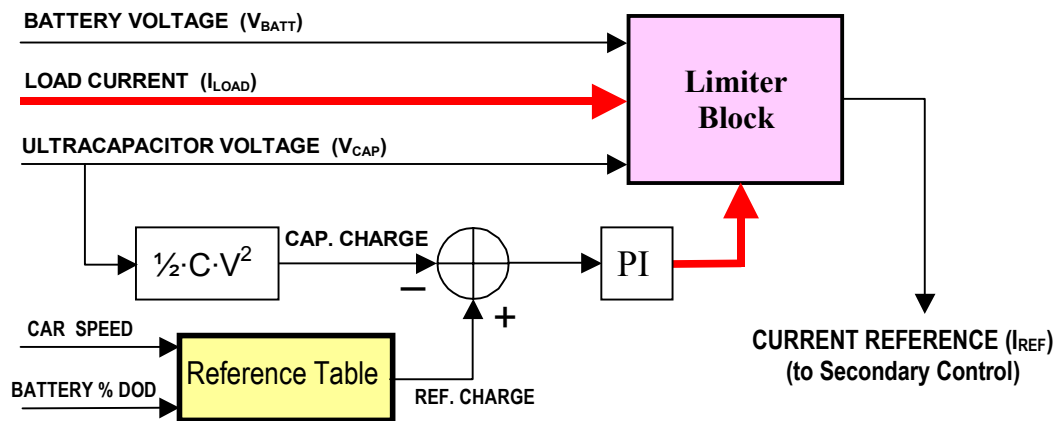

Figure 2
Primary Control

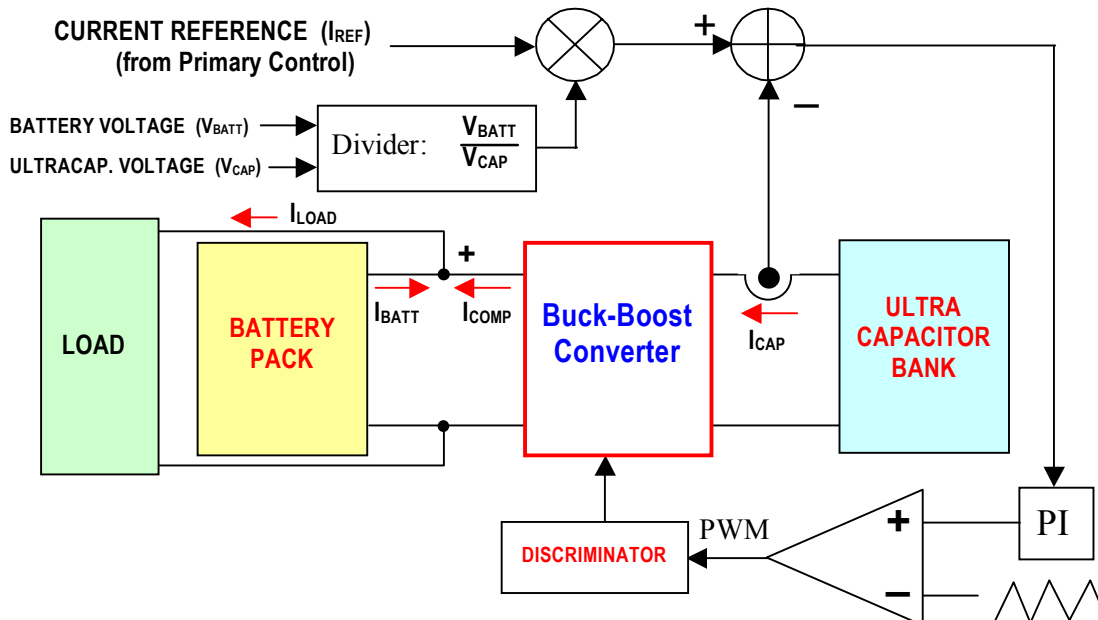

Figure 3
Secondary Control

The first duty of the *Primary Control* is to keep an adequate level of energy into the ultracapacitor. This level of energy, or charge (**REF. CHARGE** in Figure 2), is calculated through the EV speed (**CAR SPEED**), and the battery state of charge (**BATTERY % DOD**). The block named **Reference Table** in Figure 2 makes this calculation, following a criterion shown in Figure 4. The higher the speed, the lower the charge, and the higher the battery state-of-charge, the lower the charge too. The shape of these curves was estimated taking in account the time the control takes to reach the desired ultracapacitor charge.

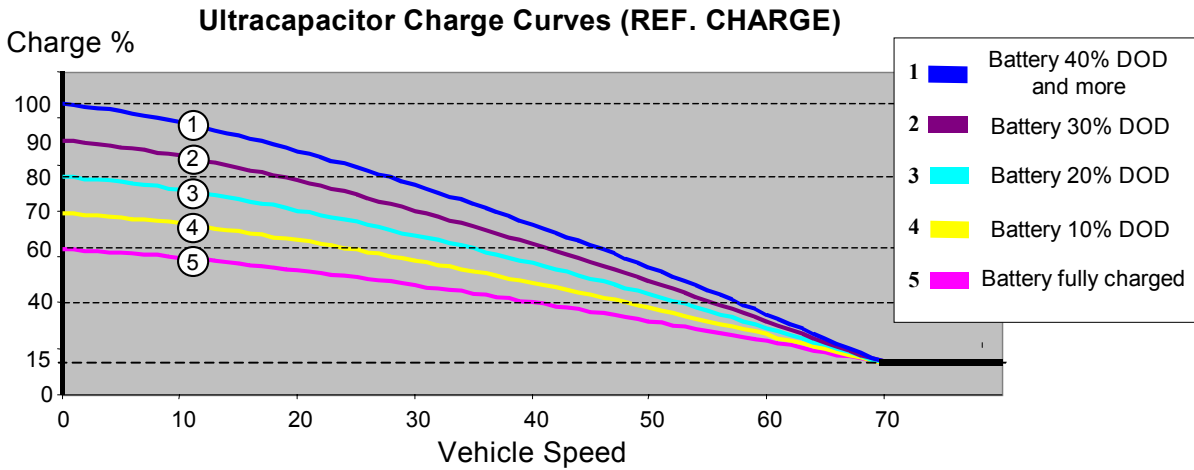

Figure 4
Family plots of the Reference Table, to evaluate the reference charge.

At the same time, the ultracapacitor voltage V_{CAP} is measured, and the actual charge is calculated. The error signal, between the reference charge and the actual charge is passed through a PI control, which evaluates the amount of **CURRENT REFERENCE** (I_{REF}), necessary to maintain the ultracapacitor bank with the desired amount of energy. This **CURRENT REFERENCE** finally goes to the *Secondary Control* of Figure 3, and defines the amount of current I_{COMP} , required to compensate the capacitor charge. The current I_{COMP} comes from the ultracapacitor through the Buck-Boost Converter (see Figure 3). When the ultracapacitor is being charged, I_{COM} becomes negative, which means, it goes in the opposite direction indicated in Figure 3. The **DISCRIMINATOR** block in Figure 3, defines when the converter works under Buck operation to charge the ultracapacitor (negative current or regeneration), or when it works under Boost operation (I_{COM} positive or acceleration).

All the process explained in the previous paragraph, to maintain an adequate charge into the ultracapacitor, is followed accordingly. However, if the battery voltage (V_{BATT}) exceeds their minimum and maximum settings, I_{REF} is modified. A similar action is performed when the ultracapacitor voltage V_{CAP} is too low or too high. The **LOAD CURRENT** (I_{LOAD}) is also an important reference inside the Primary Control. When this current exceeds the maximum absolute values set on the battery pack (I_{BATT}), the **CURRENT REFERENCE** (I_{REF}) is also modified. Then, to take in account all these situations, some logical rules have been implemented. These rules are programmed inside the **Limiter Block** shown in Figure 2. The following equations explain how the **Limiter Block** works:

$$I_{BATT} = I_{LOAD} - I_{COMP} \quad (1)$$

Where I_{COMP} is the current produced (or absorbed) by the Buck-Boost Converter, which comes from energy stored into the ultracapacitor (see Figure 3). As I_{BATT} cannot exceed certain maximum absolute ratings, it is required to establish some current limits. These current limits are defined as:

$$(\text{negative limit}) \leq I_{BATT} \leq (\text{positive limit}) \quad (2)$$

The negative and positive limits of the battery current, were both set at 70 amps. However, these limits are made smaller by the **Limiter Block** when either, the battery voltage or the ultracapacitor voltage, exceeds their settings. Combining equations (1) and (2):

$$(\text{negative limit}) \leq I_{LOAD} - I_{COMP} \leq (\text{positive limit}) \quad (3)$$

As both, negative and positive battery limits were set at the same value (70 amps), they can be called I_{BATT}^{LIMIT} . Then, from (1), (2), and (3), the **Limiter Block** performs the following action:

$$I_{LOAD} - I_{BATT}^{LIMIT} \leq I_{COMP} \leq I_{LOAD} + I_{BATT}^{LIMIT} \quad (4)$$

In simple words, what the **Limiter Block** does, is calculate a band around the vehicle's current I_{LOAD} , setting the I_{COMP} current within this band. This band is the one that maintains the battery current and voltage within limits. The Limiter Block action is shown in Figure 5. The difference between I_{LOAD} and I_{COMP} , ΔI , is the battery current, which cannot be higher than ± 70 [A].

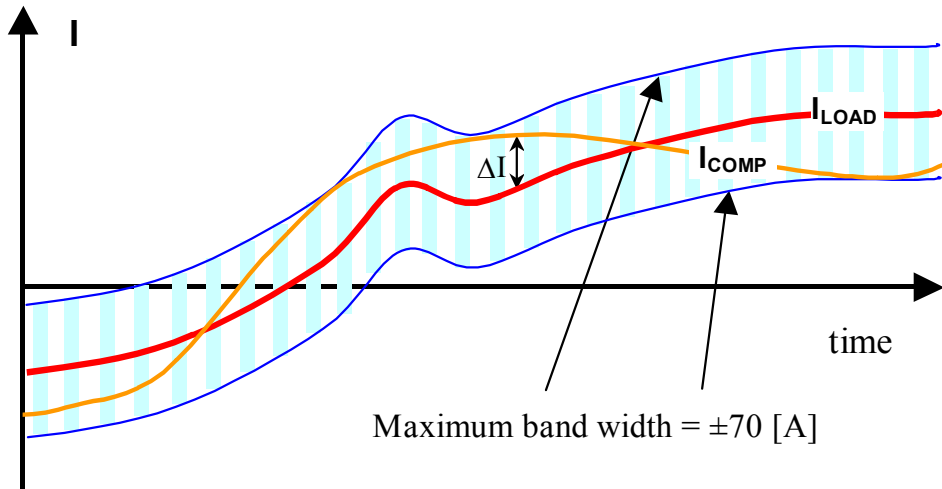

Figure 5
Limiter Block action.

Simulation Software

To simulate the system, a power electronics simulator called PSIM was used [6]. The PSIM software is a computational tool which runs faster than Spice, and has many simulation modules such as brushless dc motors, look-up tables, sensors, control blocks, power inverters, and so.

For the implementation of the *Primary Control*, C++ routines were used, which were compiled as DLL archives. This strategy was required because of the high complexity of this control, which is not possible to program with the PSIM software alone. For special functions, such as the Limiter Block, some routines of the software Matlab were used. The Figure 6 shows the circuit topology given by the PSIM program. The **Limiter Block** and the **PI** control of the *Primary Control* were programmed inside the block called DLL. Two Look-up tables define: a) the load current I_{LOAD} , and b) the family plots of the **Reference Table** for the ultracapacitor. The battery pack is simulated using a subcircuit, which is shown in Figure 7 (**Battery Subcircuit**). This equivalent circuit for the battery pack takes in account, the internal resistance, and the percentage of DOD, through a look-up table and an integrative process.

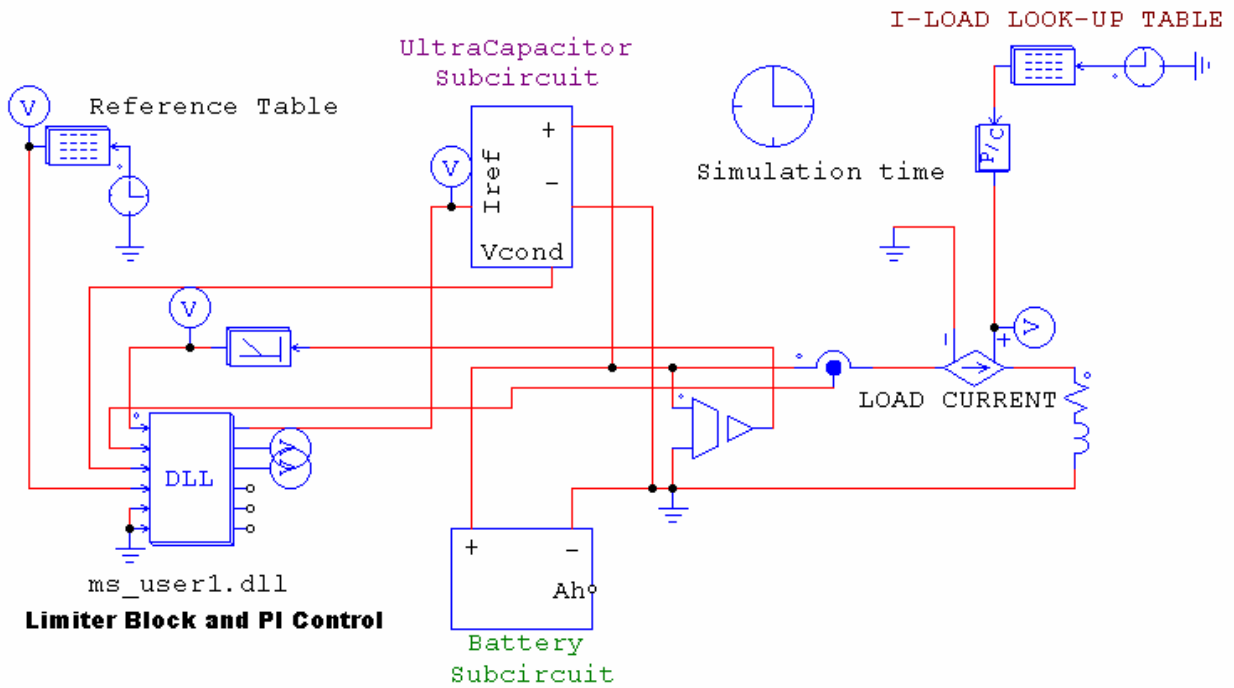

Figure 6
Software simulation example

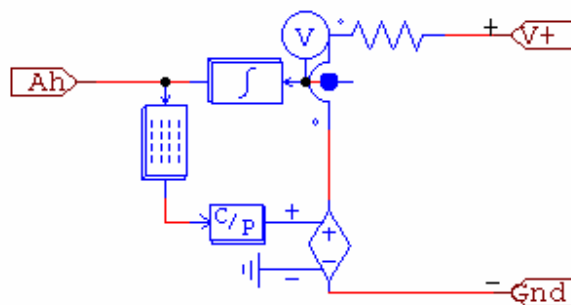

Figure 7
Battery Subcircuit

The block called “**UltraCapacitor Subcircuit**” in Figure 6, comprises all the *Secondary Control*, as shown in Figure 8. This figure shows the Buck-Boost converter, and all the control associated with the *Secondary Control*. The **DISCRIMINATOR** also has a subcircuit, which is shown in the lower-right side of Figure 8.

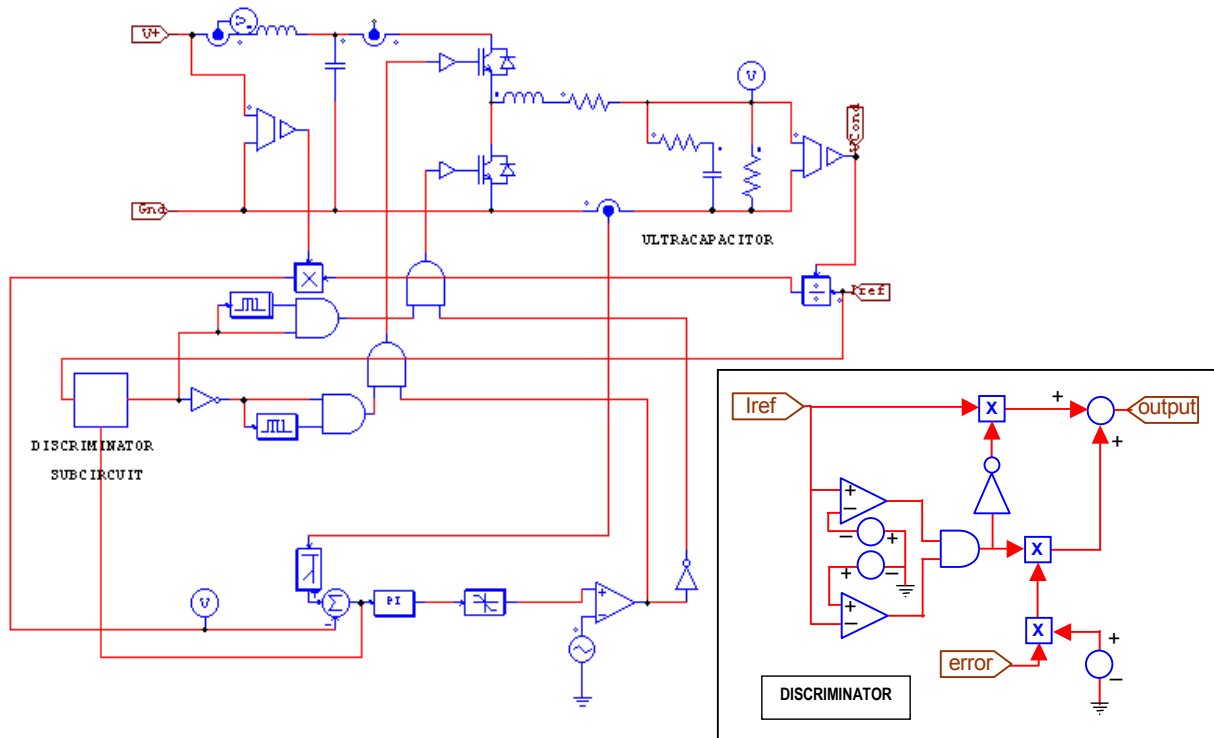

Figure 8
Ultracapacitor Subcircuit

Simulation Results

The next oscillograms show the results obtained with the PSIM Software mentioned in the previous section. Many different situations were simulated. To make the results more real, some experiments with the electric vehicle were performed on the streets. These experiments allowed to evaluate the time the vehicle needs, and the current and voltage variations during acceleration, and regenerative braking. These experiments showed that the vehicle can accelerate from 40 to 60 [km/h] in a little more than 4 seconds, and that the maximum current taken from the battery reaches 200 amps. When the vehicle reaches steady-state at 60 [km/h], the battery current goes down at a constant value of around 20 [A]. With this result, the system proposed was simulated. The result of this simulation (from 40 to 60 [km/h]) is shown in Figure 9. This figure displays the battery voltage V_{BATT} , the ultracapacitor voltage V_{CAP} , the load current to accelerate the car I_{LOAD} , the battery current I_{BATT} , and the compensation current I_{COMP} that comes from the energy stored in the ultracapacitor. The settings for the battery into the control were: $V_{min}=300$ Vdc, and $V_{max}=360$ Vdc; $I_{min}=-70$ Adc, and $I_{max}=70$ Adc.

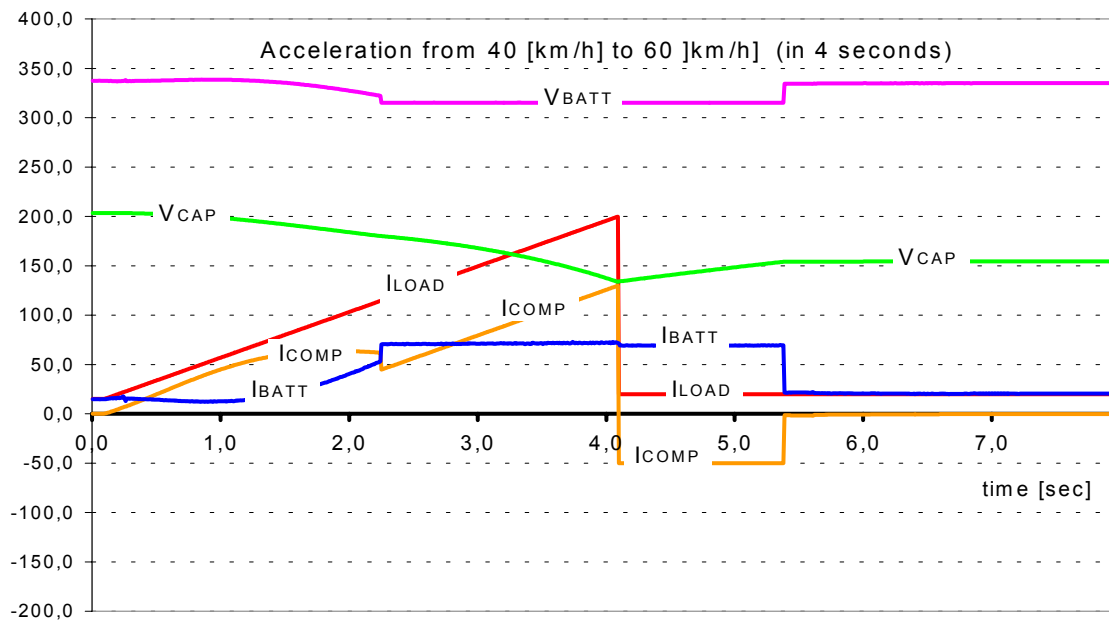

Figure 9
Acceleration from 40 to 60 [km/h]

When the load current begins to increase, most of the current is taken from I_{COMP} , which comes from energy stored into the ultracapacitor. As the capacitor voltage V_{CAP} decreases (energy is going down), more current begin to be taken from the battery, but when the battery reaches its limit (70 amps.), the capacitor is forced to give all the current in excess of 70 [A]. This action produces a faster decrease in the ultracapacitor voltage. If the capacitor voltage reaches its minimum setting (120 Vdc with a maximum of 360 Vdc), then the vehicle should not be able to continue accelerating, because at this point, 90% of the capacitor energy would have been used. If the capacitor is large enough (as in this case), this situation will not happens, and the capacitor will be able to end its duty. Later on, the capacitor will be able to recover energy, once the vehicle reaches constant speed. This case is also shown in the Figure 9. When the EV reaches constant speed (60 km/h), the compensating current I_{COMP} becomes negative, charging the capacitor. As the car is not braking, this energy is being taken from the battery, but at a maximum value given by the limit set by the controller (70 Adc). Once the capacitor recovers its energy, the battery current goes down, as shown in the final seconds of simulations in Figure 9. Finally, when the ultracapacitor recovers the energy, which corresponds to the value given by the **Reference Table** of Figure 4, the Buck-Boost converter is inhibited, and the load current takes power only from the battery pack.

A second simulation, displayed in Figure 10, shows a deceleration from 40 [km/h] to stop. This regenerative action takes 2.1 seconds. The regenerative current goes from 200 Adc to zero in the time indicated above. Both, the battery and the ultracapacitor, through I_{BATT} and I_{COMP} , receive this current respectively. The simulation shows that the battery receives a current smaller than the limit of 70 Adc. This happens because the maximum voltage allowable by the battery (360 Vdc) is reached first. This means that the battery is almost fully charged, and then cannot receive more than 30 Adc approximately. For this reason, most of the current is taken by the ultracapacitor. Once the vehicle stops, the battery continues charging the capacitor until it reaches its final charge (the Reference Table of Figure 4 gives the required amount of charge). In this case the amount of energy stored in the ultracapacitor corresponds to a voltage of around 260 Vdc.

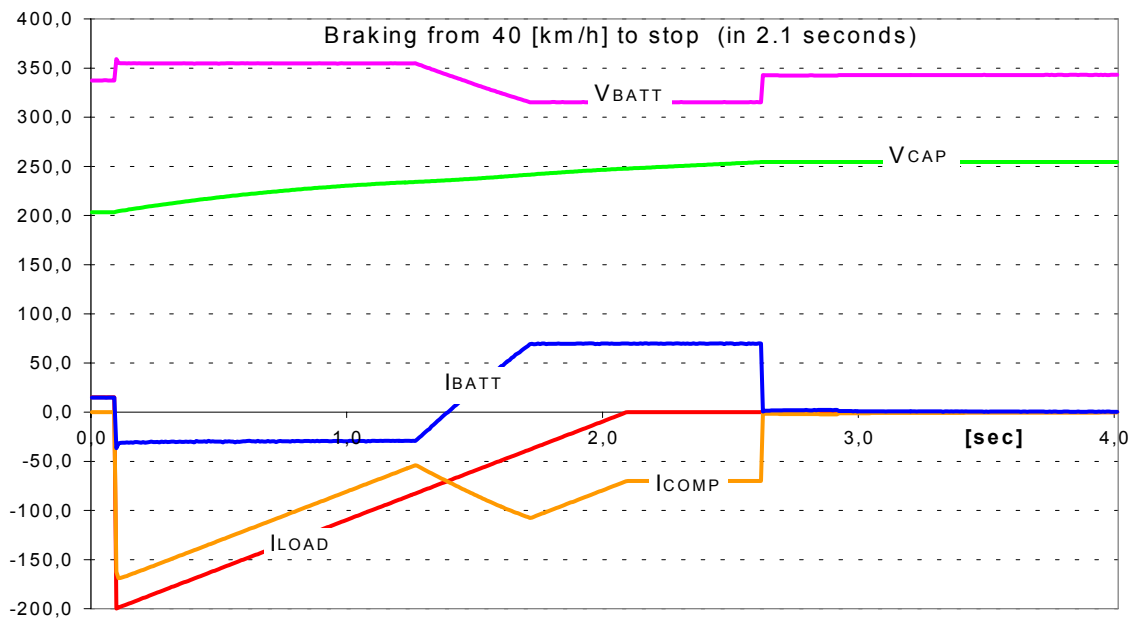

Figure 10
Braking from 40 [km/h] to zero

It can be noted that the battery current begins to be positive before the vehicle reaches zero speed. This is because the capacitor needs to have more energy at that particular speed, and then the control begins to charge the capacitor in advance.

Conclusions

An ultracapacitor bank for an Electric Vehicle has been simulated. The purpose of this device is to allow higher accelerations and decelerations of the vehicle with minimal loss of energy, and minimal degradation of the main battery pack. The system uses an IGBT Buck-Boost converter, and the control of the system measures the battery voltage, the battery state-of-charge, the car speed, the instantaneous currents in both the terminals (load and ultracapacitor), and the actual voltage of the ultracapacitor. The simulations showed that the control system can work properly, taking in account all the aforementioned variables. Next step in this work is to implement and install the ultracapacitor system in an electric car. This car is a Chevrolet LUV truck, similar in shape and size to a Chevrolet S-10, which was already converted to an electric car at the Catholic University of Chile.

It is interesting to mention that, if ultracapacitor reaches in the future, a specific energy of at least 20 Wh/kg (at this moment some laboratory samples reach 10 Wh/kg), it will be possible to implement EVs with ultracapacitors only. They could give a range of 100 kms with a 500 kgs capacitor bank, with very short charging time and excellent life expectancy. The EV will be able to be fully charged in few minutes. Besides, the ultracapacitor could last all the vehicle useful life.

Acknowledgments

The authors want to thank Conicyt through the project Fondecyt N° 1990097, for the financial support given to this work.

References

1. Maxwell. *Ultracapacitors Data sheets and technical information for 1,000 and 2,500 Farads*, [Maxwell publications]
2. Jun Takehara, and Kuniaki Miyaoka, *EV Mini-Van Featuring Series Conjunction of Ultracapacitors and Batteries for Load Leveling of its Batteries*, Technical Research Center, The Chugoku Electric Power Co., Inc., 3-9-1 Kagamiyama, Higashihiroshima-City, Hiroshima 739, Japan. 14th Electric Vehicle Symposium, 1996 [on CD ROM].
3. L. A. Viterna, *Ultra-Capacitor Energy Storage in a Large Hybrid Electric Bus*, NASA Lewis Research Center, 21000 Brookpark Rd., Cleveland, Ohio 44135. 14th Electric Vehicle Symposium, 1996 [on CD ROM].
4. F. Caricchi, F. Crescimbin, F. Giulii Capponi, L. Solero, *Ultracapacitors Employment in Supply Systems for EV Motor Drives: Theoretical Study and Experimental Results*, University of Rome. 14th Electric Vehicle Symposium, 1996 [on CD ROM].
5. A. F. Burke, *Electrochemical Capacitors for Electric Vehicles. Technology Update and Implementation Considerations*, University of California at Davis, EVS-12 Symposium Proceedings, pp.27-36, 1996.
6. Powersim Technologies. *PSIM Version 4.1, for Power Electronics Simulations. User Manual*. Powersim Technologies, Vancouver, Canada, <http://www.powersimtech.com>.