

A Fault Protection Scheme for Series Active Power Filters

Luis A. Morán, *Senior Member, IEEE*, Ivar Pastorini, Juan Dixon, *Senior Member, IEEE*,
and Rogel Wallace, *Associate Member, IEEE*

Abstract—A protection scheme for series active power filters is presented and analyzed in this paper. The proposed scheme protects series active power filters when short-circuit faults occur in the power distribution system. The principal protection element is a varistor, which is connected in parallel to the secondary of each current transformer. The current transformers used to connect in series the active power filter present a low-magnetic saturation characteristic increasing current ratio error when high currents circulate through the primary winding, thus generating lower secondary currents. In this way, the power dissipated by the varistors is significantly reduced. After a few cycles of short-circuit currents flowing through the varistor, the gating signals applied to the active power filter switches are removed and the pulsewidth-modulation (PWM) voltage-source inverter (VSI) is short circuited through a couple of antiparallel thyristors.

Index Terms— Current transformer, pulsewidth-modulation voltage-source inverter, series active power filter, varistor.

I. INTRODUCTION

SERIES ACTIVE power filters have proved to be an interesting and viable solution for reactive power and current harmonic compensation [1]–[6]. With an appropriate control strategy, they can compensate current harmonics and voltage unbalance in three- and four-wires power distribution systems [3], [4]. The small power rating required by series active power filters allow their implementation with low-cost pulsewidth-modulation (PWM) voltage-source inverters (VSI's) [4]–[6], suitable for compensation of high-power nonlinear loads. However, the main disadvantage of this type of compensator is that requires a special protection scheme since it cannot be protected with normal circuit breakers or power fuses. When a short circuit occurs in the power distribution system, larger currents flow through the primary of the current transformers, generating dangerous voltages and currents in the secondary windings and damaging the PWM-VSI.

Although series active power filters have already been presented and analyzed in the technical literature [1]–[6], no information is available concerning their behavior when short-circuit currents flow through the power distribution system. Previously reported literature discusses series active power

filters in terms of principles of operation and compensation characteristics. Control circuit design for normal operating conditions have also been discussed, but no one has analyzed and proposed a protection scheme for this type of compensation system.

The protection scheme topology presented in this paper is shown in Figs. 1 and 2. It consists of a varistor connected in parallel to the secondary winding of each current transformer (CT) and a couple of antiparallel thyristors. A special and simple circuit detects the amplitude of the current flowing through the varistors and generates the gating signals of the antiparallel thyristors. The protection circuit of the series active power filter must protect only the PWM-VSI connected to the secondary of the current transformer and must not interfere with the protection scheme of the power distribution system. Since the primary of the active power filter transformers are connected in series to the power distribution system, they operate as current transformers, so that their secondary windings cannot operate in open circuit. For this reason, if a short circuit is detected in the power distribution system, the PWM-VSI cannot be disconnected from the secondary of the current transformer. Therefore, the protection scheme must be able to limit the amplitude of the currents and voltages generated in the secondary circuits until the power system fault is cleared or the PWM-VSI is isolated. This task is performed by the varistors, thyristors, and magnetic saturation characteristic of the transformers.

The main advantages of the proposed series active power filter protection scheme are as follows.

- 1) It is simple and easy to implement.
- 2) It offers full protection against power distribution short-circuit currents.
- 3) It does not interfere with the power distribution system.

Finally, the viability of the proposed protection scheme is verified by simulation with PSPICE and with an experimental setup of 5 kVA.

II. PRINCIPLES OF OPERATION

Short circuits in power distribution systems generate large currents that flow through the power lines until the circuit breaker operates clearing the fault. The total clearing time of a short circuit current depends on the time delay imposed by the protection system. The clearing time cannot be instantaneous due to the operating time imposed by the coordination requirement of the overcurrent relay and by the total interruption time of the power circuit breaker. Total clearing time of a low-

Manuscript received January 10, 1999; revised February 1, 1999. This work was supported by Fondecyt-Chile under Project 1960572. Recommended by Associate Editor, L. Xu.

L. A. Morán, I. Pastorini, and R. Wallace are with the Department of Electrical Engineering, Universidad de Concepción, Concepción, Chile (e-mail: l Moran@manet.die.udec.cl).

J. Dixon is with the Department of Electrical Engineering, Universidad Católica de Chile, Santiago, Chile (e-mail: jdixon@ing.puc.cl).

Publisher Item Identifier S 0885-8993(99)07285-3.

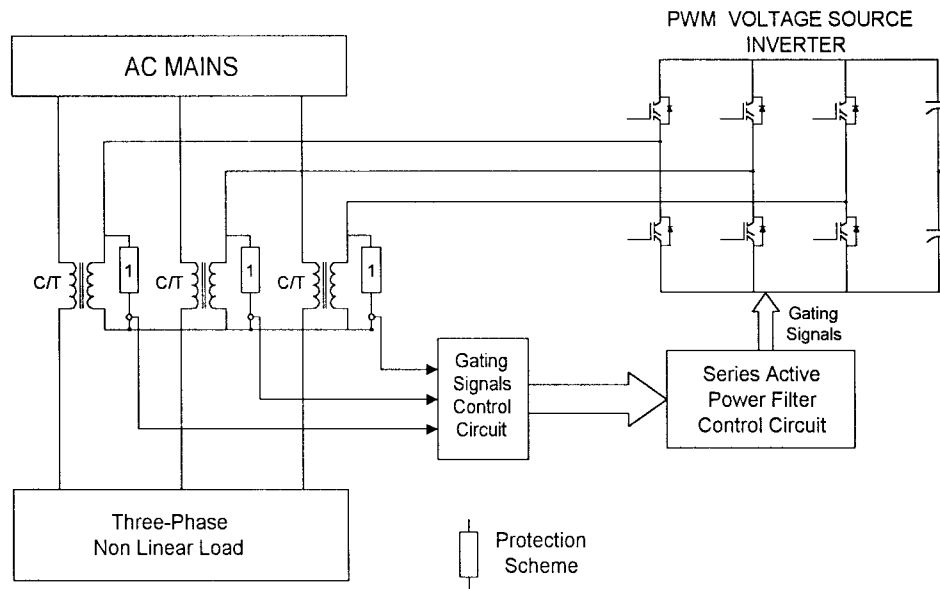

Fig. 1. The series active power filter and the proposed protection scheme.

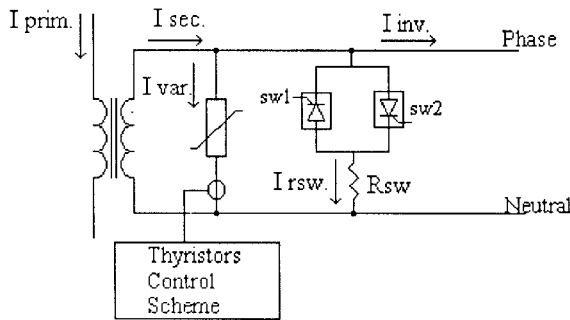

Fig. 2. The proposed protection scheme.

voltage circuit breaker depends on the amplitude of the current fault, but usually has a minimum value higher than 45 ms, as shown in Fig. 3 [7]. For medium-voltage application, the total minimum clearing time exceeds 100 ms. Although power system equipment, such as power transformers, cables, buses, etc., are designed to withstand short circuit current during at least ten cycles, the series active power filter may suffer severe damage during this short time. The withstand capability of the series active power filter depends mainly on the inverter power semiconductor characteristics.

Since the most important feature of series active power filters is the small rated power required to compensate the power system, typically 10%–15% of the load rated apparent power [3], the inverter semiconductors are rated for low values of blocking voltages and continuous currents. This makes series active power filters more vulnerable to power system faults.

If a short-circuit fault appears in the power distribution system, a large voltage will be generated in the secondary of the current transformer, affecting the normal operation of the active power filter. This large voltage will force the circulation of high currents through the inverter, and will increase the voltage across the inverter ac terminals, as shown in Fig. 4(b). For these reasons, the protection scheme must be able to reduce

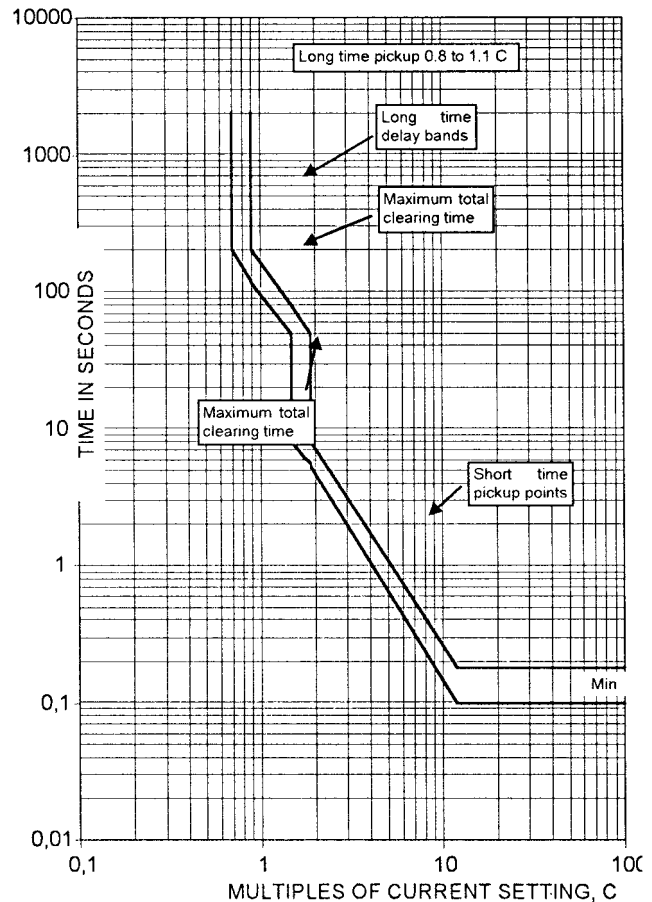

Fig. 3. Time-current characteristic of a low-voltage molded case power circuit breaker.

the reflected voltage, without disconnecting the VSI since the secondary windings of the CT cannot operate in open circuit. Moreover, the ac terminals of the VSI cannot be short circuited due to the electrolytic capacitor connected across the dc bus (see Fig. 1).

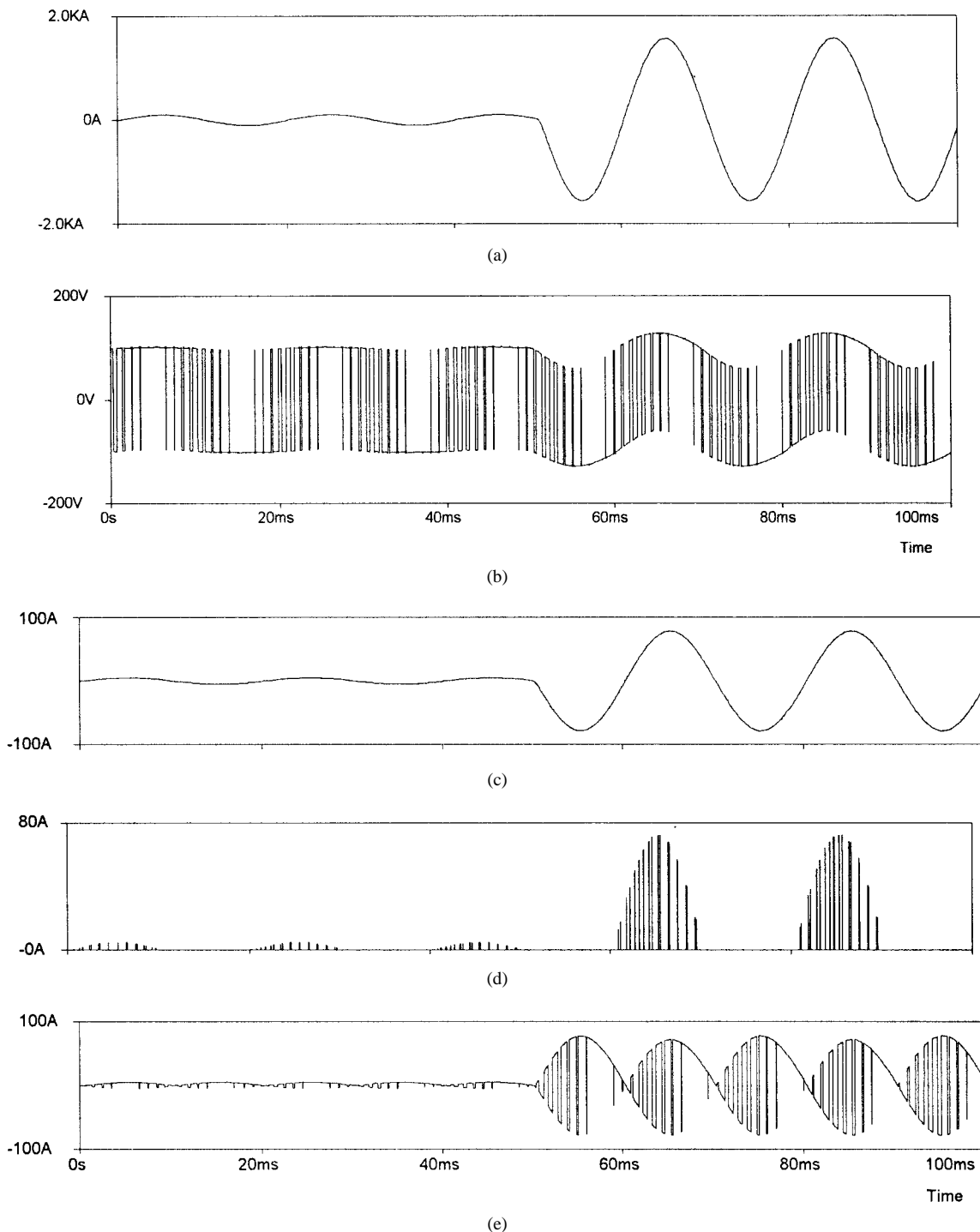

Fig. 4. Simulated results for a line-to-line short circuit fault at 50 ms: (a) power distribution system line current, (b) current transformer secondary voltage, (c) inverter ac current, (d) current through an inverter leg, and (e) inverter dc bus current.

By using the protection scheme proposed in this paper and shown in Fig. 2, the voltage and currents reflected in the secondary of the CT are significantly reduced. When short-circuit currents circulate through the power distribution system, the low-saturation characteristic of the current transformers increases the current ratio error and reduces the amplitude of the secondary voltage and currents. Moreover, the saturated high secondary voltages induced by the primary short-circuit currents are clamped by the varistors, reducing the amplitude of the PWM-VSI ac currents.

Once the secondary current exceeds a predefined reference value, the PWM-VSI is bypassed through a couple of antiparallel thyristors, and then the gating signals applied to the PWM-VSI are removed. In this way, the PWM-VSI can be isolated from the power system fault. The secondary short-circuit currents will circulate through the antiparallel thyristors and the varistors until the fault is cleared by the protection equipment of the power distribution system. Since the primary of the current transformer is designed to withstand short-circuit currents during at least one second (thermal short-time rating),

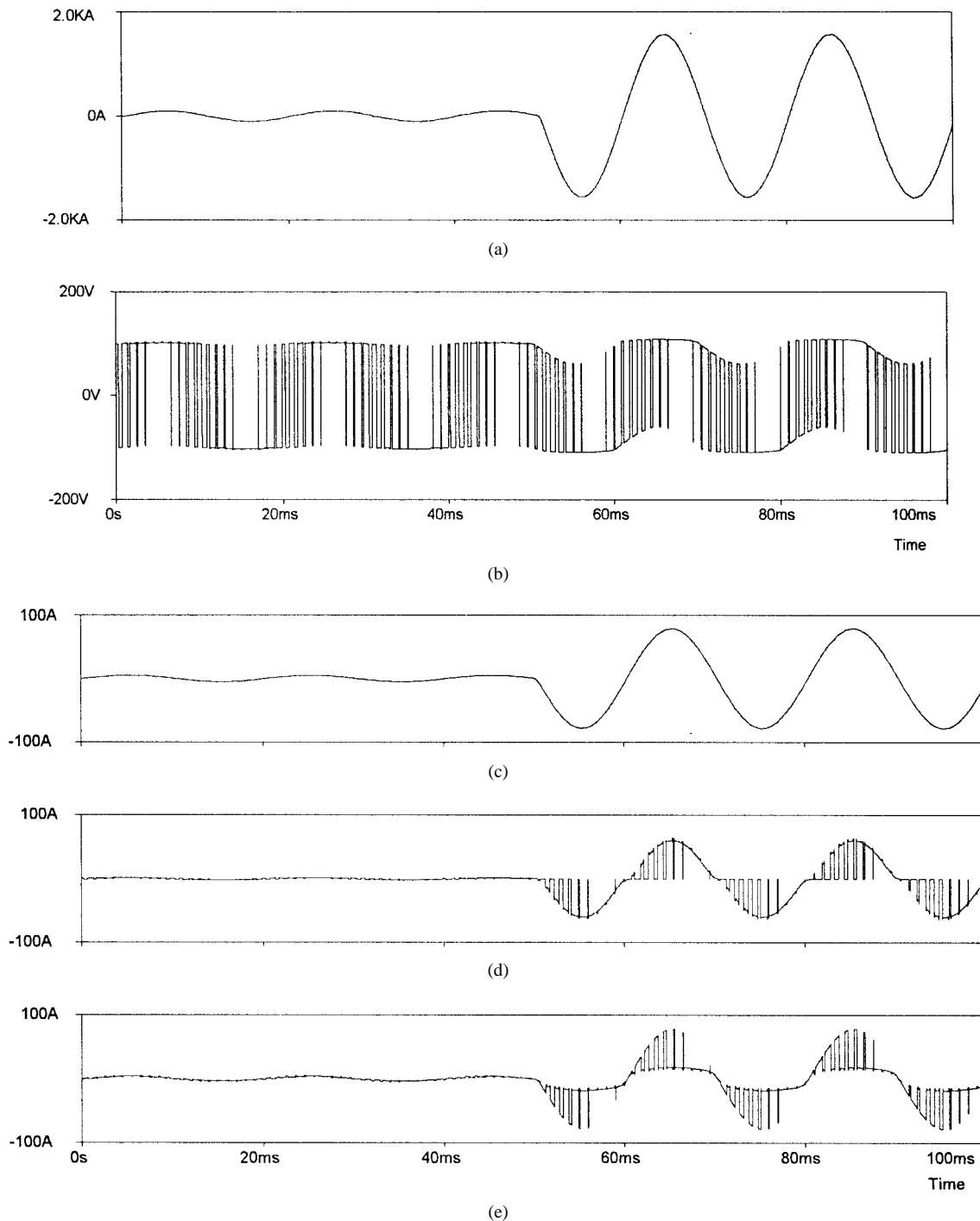

Fig. 5. Simulated results for a line-to-line short circuit in the power distribution system. The protection scheme is implemented only with the varistor: (a) primary current, (b) secondary voltage, (c) secondary current, (d) current through the varistor, and (e) inverter ac current.

its protection depends on the clearing time of the power circuit breaker. The principles of operation and the effectiveness of the protection scheme are shown in Figs. 5–7.

By using a couple of antiparallel thyristors the energy dissipated in the varistor is reduced, as shown in Fig. 6.

By using a current transformer with low-saturation characteristics, the waveforms shown in Fig. 7 are obtained.

Fig. 7 shows the effective reduction in the value of the secondary current that can be achieved by using a CT with low-saturation characteristics. By increasing the current ratio

error due to the magnetic saturation, the energy dissipated in the secondary of the CT is significantly reduced. The total energy dissipated in the varistor for the different simulated conditions shown in Figs. 5–7 is given in Fig. 8.

III. SPECIFICATION CRITERIA

A. Current Transformers

Normally, current transformers are specified for applications in protection systems or in instrumentation. The main

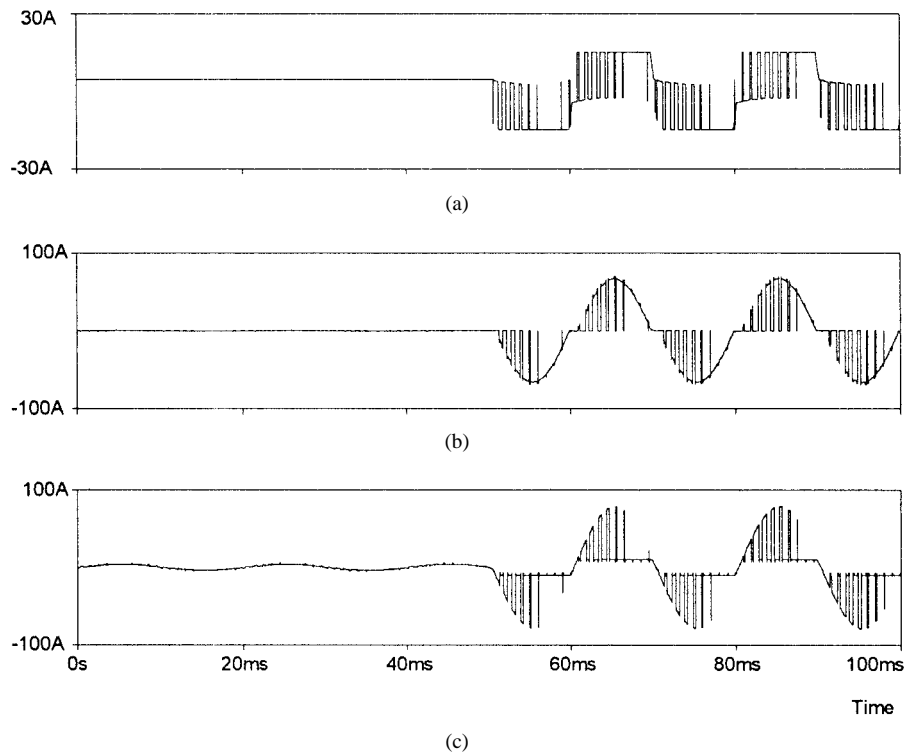

Fig. 6. Simulated results for a line-to-line short circuit in the power distribution system. The protection scheme is implemented with the varistor and a couple of antiparallel thyristors: (a) current through the varistor, (b) current through the thyristors, and (c) inverter ac current.

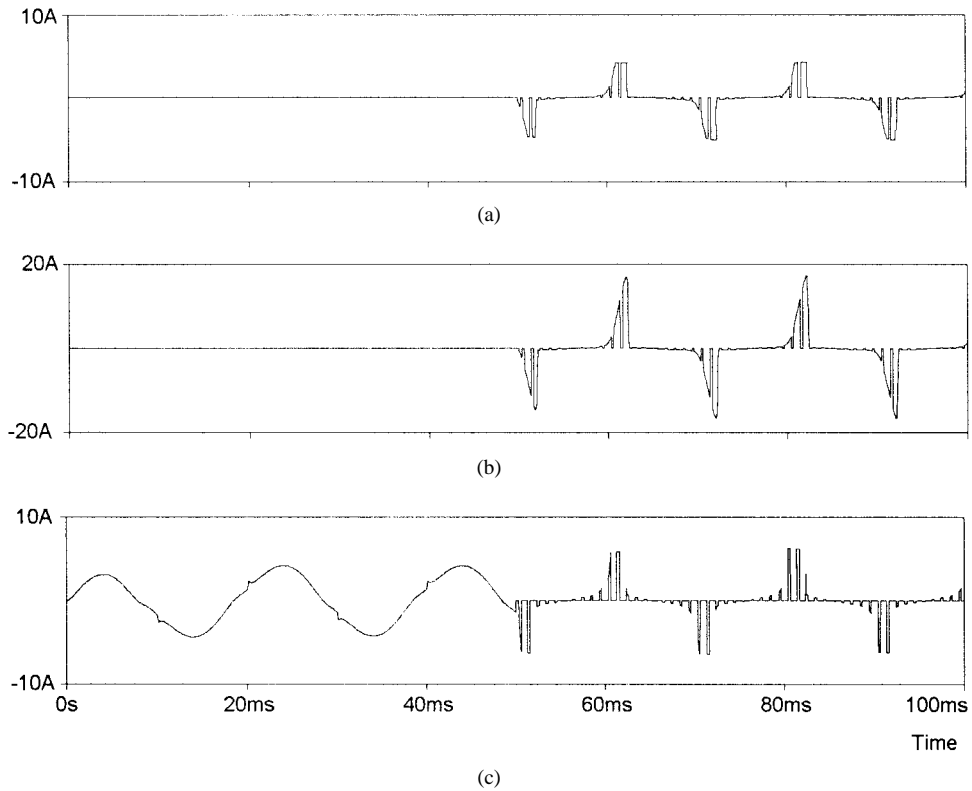

Fig. 7. Simulated results for a line-to-line short circuit in the power distribution system. The protection scheme is implemented with the varistor, a couple of antiparallel thyristors, and a CT with low-saturation characteristic: (a) current through the varistor, (b) current through the thyristors, and (c) inverter ac current.

difference between these two types of current transformers is related with the turn ratio accuracy at fault current levels. The accuracy at high overcurrent depends on the saturation

characteristic of the magnetic core. Saturation results in a rapid increase of the current ratio error and in a high distortion of the secondary current transformer waveform as shown in Fig. 9.

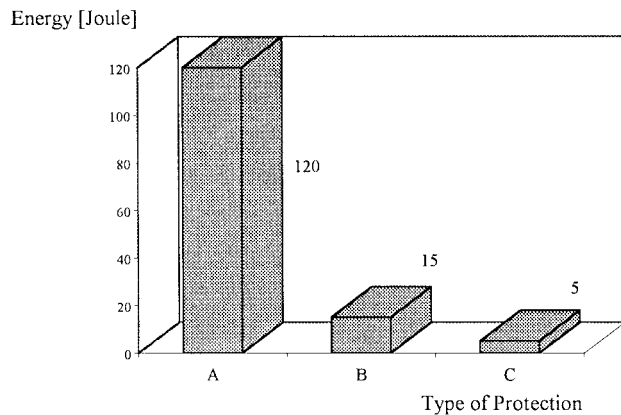

Fig. 8. The total energy dissipated in the varistor during the power system short circuit for different protection schemes implementations only when: (a) the varistor is used, (b) varistor is connected in parallel to a bidirectional switch, and (c) the complete protection scheme is operating (including the CT with low-saturation characteristics).

During the saturation of the transformer the secondary current can be described as a large spike of current lasting less than 4 ms each half cycle.

Current transformers used in protection systems present a ratio error below 10% at any current value from 1 to 20 times the rated current at standard burden. For current transformer used in instrumentation, saturation occurs at five times the rated current [7].

The protection scheme implemented for the series active power filter requires a current transformer with a low-saturation point in order to provide an effective protection of the VSI. For this reason, CT's used for protection or instrumentation cannot be used, unless they had been specified to operate with a low-rated burden. However, since the equivalent impedance of the inverter depends on the compensation characteristics (i.e., the inverter ac output voltages and ac currents are changing continuously), it is preferable to use a special current transformer with a low-saturation characteristic, that means the saturation should start at two–three times the primary rated current.

The hysteresis curves of the 4% silicon–iron core used for the construction of the current transformers are shown in Fig. 10. Fig. 10(a) shows the hysteresis curve for rated operating conditions and Fig. 10(b) illustrates how the magnetic characteristic of the same CT changes due to the saturation effect. The saturation point for this type of material starts at 1.5 [T].

Fig. 9 shows that due to the saturation of the CT's the secondary currents are significantly reduced and distorted. This affects the compensation characteristic of the active power filter. However, since the power system is operating under fault conditions, compensation is not required.

The turn ratio of the current transformers is 1:20. For a CT with a high-saturation point, if the amplitude of the primary current is 1300 A, the reflected secondary current reaches 65 A, which means that the CT is operating in the linear region. For a current transformer with a low-saturation point, the reflected secondary current reaches only 11 A, for the same primary current, although the current waveform

is more distorted. The reduction in the amplitude of the secondary current due to the saturation is very convenient for the proposed protection scheme.

B. Varistor

A varistor operates as a nonlinear variable impedance. The relationship between the current in the device, I , and the voltage across the terminals, V , is typically described by the equation: $I = kV^\alpha$. The term α in the equation represents the degree of nonlinearity of the conduction. The higher the value of α , the better the clamp, which explains why α is sometimes used as a figure of merit (see Fig. 11).

For most of the applications, the selection and specification of a varistor considers the following five-step process.

- 1) Determine the required steady-state voltage rating (dc or rms value).
- 2) Establish the transient energy absorbed by the varistor (during 10 μ s to 1 ms).
- 3) Calculate the peak transient current through the varistor (during 8–20- μ s interval).
- 4) Determine the power dissipation requirements.
- 5) Select a model to provide the required voltage clamping characteristic.

The most important data required for the correct specification of a voltage suppressor or varistor is the maximum transient energy absorbed by the device during 10 μ s to 1 ms and the related power dissipation requirements. These two characteristics are difficult to evaluate, since they depend on the type of failure or transient that generates the overvoltage.

Varistors can be connected in series to provide different voltage protection levels from the standard voltage available. Also, varistors can be paralleled to conduct more current than a single device. However, matching their characteristics so the paralleled devices can share the current equally is an extremely difficult and complex procedure. One of the paralleled varistors will always conduct most of the current leading to an early failure of the device and defeating the purpose of paralleling. For this reason, and in order to increase the reliability of the protection scheme, a couple of antiparallel thyristors are connected in parallel to the varistor. In this way, a current divider is provided decreasing the amount of energy dissipated in the varistor.

The total energy dissipated by the varistor can be calculated using the following expression:

$$E = \int_0^T V_C(t)I(t) dt = KV_C I_T \tau \quad (1)$$

where I_T is the varistor peak current, V_C is the varistor clamp voltage, τ is the transient duration time, and K is a constant that depends on the varistor current waveform. For the current waveform shown in Fig. 12, $K = 0.637$ [8].

For example, if a GE-MOV II varistor, Z series, model V150AZ is used to protect the PWM-VSI shown in Fig. 1, the total energy dissipated during one cycle (20 ms) of the current fault is equal to

$$E = 2KV_C I_T \tau = 2(0.637)(150)(80)3.7 \times 10^{-3} = 94.28 \text{ J.}$$

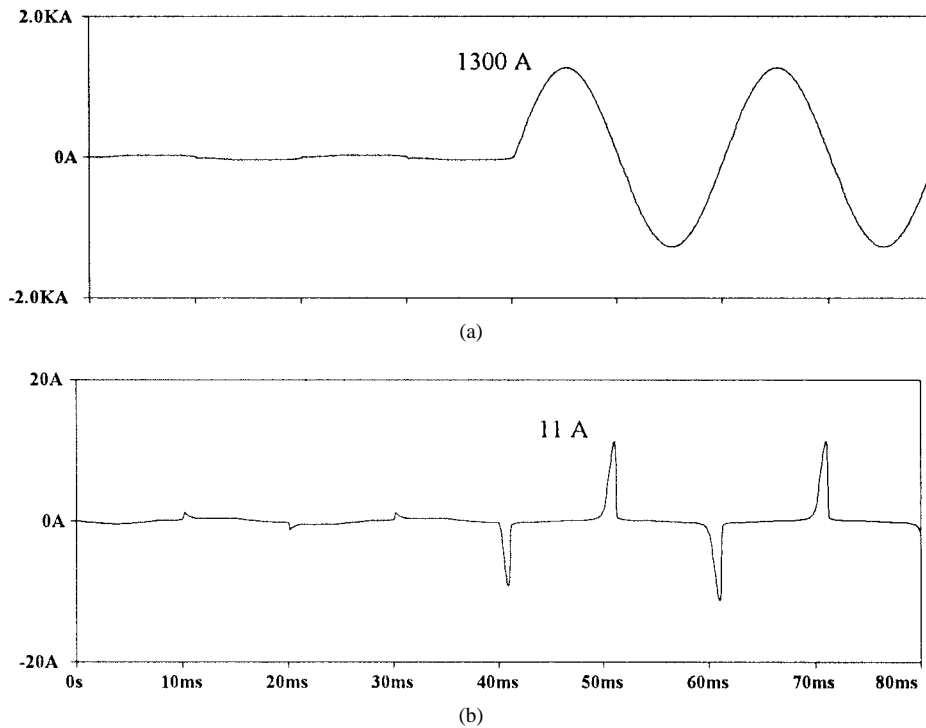

Fig. 9. Current waveforms of a CT with low-magnetic saturation characteristics: (a) primary current and (b) secondary current.

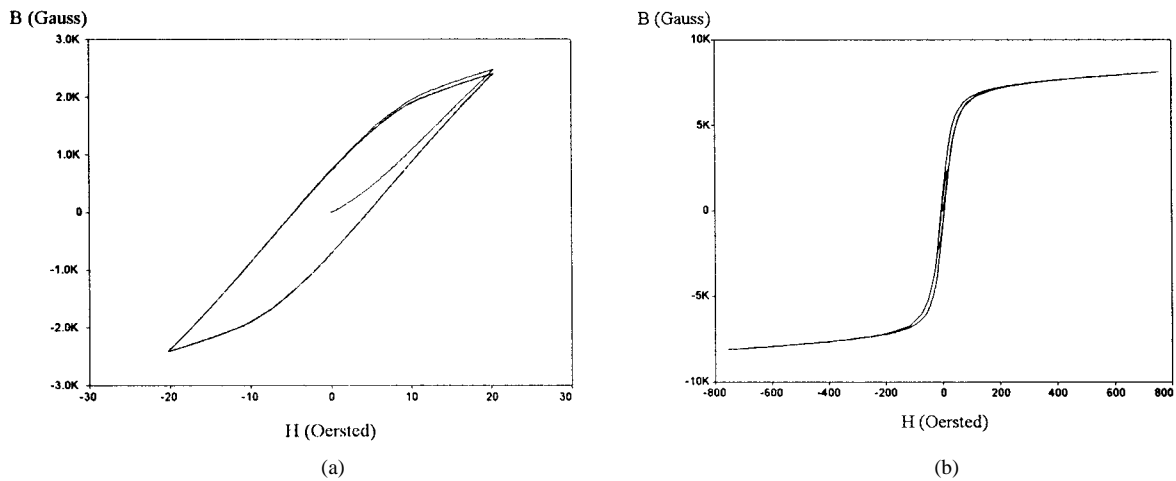

Fig. 10. Hysteresis curve for a 4% silicon-iron magnetic material: (a) CT operating at rated conditions and (b) CT operating under short circuit.

The maximum energy that this varistor can dissipate during 1 ms is only 30 J.

Another important feature of the varistor is the response time. The new family of varistors made of sintered metal oxides primarily zinc oxide with suitable additives presents response times in the order of nanoseconds (between 35–50 ns) and a considerably greater values of α between 15–30. These characteristics compare favorably with previous surge suppression technologies, such as gas discharge tubes and SCR's in which the response time is in the order of microseconds.

The varistor may also be evaluated on the basis of how many times will conduct a given current for a defined time period. For example, if the transient requires the varistor to conduct 200 A for 20 μ s, a 20-mm-diameter metal-oxide varistor (MOV) could suppress it 10 000 times before possible

failure [8]. However, if the transient is 200 A for 1 ms, the 20-mm device could suppress it only once before failure. For these reasons, and since it is impossible to control the amount of energy that the varistor will dissipate, it is convenient to connect a bidirectional switch in parallel. In that way, an important part of the transient current flowing through the thyristor will circulate by the switch.

C. The Current Divider Circuit

The current divider circuit is implemented with a couple of antiparallel thyristors connected in series to a resistance, R_{TH} . The control circuit that generates the gating signals to the thyristors is simple and is shown in Fig. 13. The thyristors must be rated to withstand the maximum transient current of the varistor I_T and must be able to dissipate an energy higher

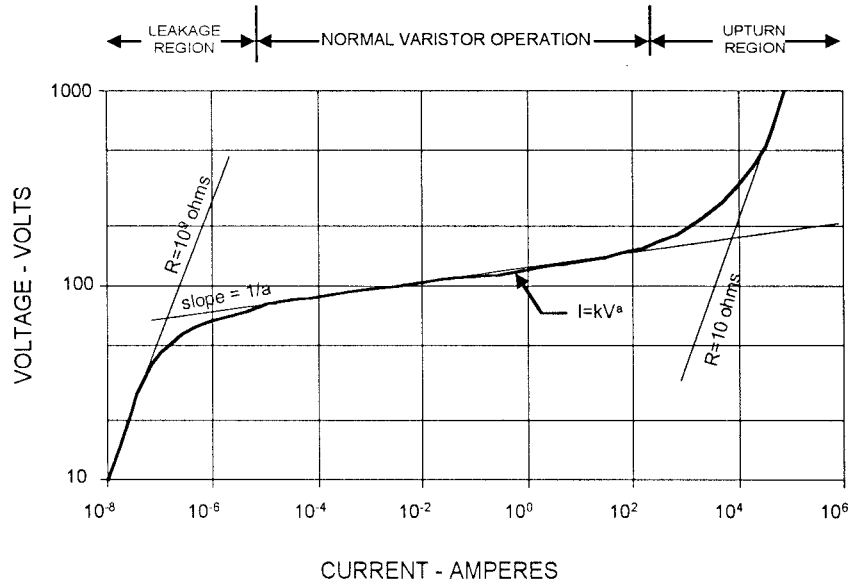

Fig. 11. The voltage/current characteristic of a varistor.

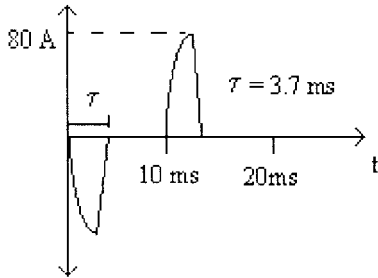

Fig. 12. The current waveform flowing through the varistor during the power system short circuit.

than the one dissipated by the varistor. In other words, the I^2t of the thyristor should be at least two times higher than the W_{TM} of the varistor.

The control circuit is implemented with two comparators. A reference voltage and a voltage coming from the current sensor are the input signals of each comparator. The reference signal is fixed at a value equals to 25% of the varistor maximum transient current I_{TM} . If the signal coming from the current sensor is greater than this reference signal a current pulse is applied to the gate of the respective thyristor. The amplitude of the current that will circulate through the thyristor will depend on the impedance values of the varistor and thyristors, respectively (current divider). The resistance R_{TH} is connected in series to the antiparallel thyristors and avoids to short circuit the varistor, and the inverter dc bus. Once the thyristors start conduction, the clamp voltage of the varistor appears across the resistance R_{TH} . The value of R_{TH} must be calculated considering the $V-I$ characteristic of the varistor, and is defined by the following expression:

$$R_{TH} = \frac{V_N}{I_{TM}} \quad (2)$$

where V_N is the rated voltage of the varistor and I_{TM} is the transient peak current value that it can handle during 8–20 μ s.

R_{TH} must be smaller than the equivalent on resistance of the varistor.

Varistors initially fail in a short circuit mode when subjected to surges beyond their peak current/energy ratings. They also fail in a short circuit when are operated at steady-state voltages well beyond their ratings values. However, this latter mode of stress may result in the eventual open circuiting of the device due to the melting of the lead solder joint. If the varistor fails as an open circuit, large overvoltages will be applied to the PWM-VSI. But since the thyristors are conducting, these overvoltages are not going to be generated.

The combined effect of the low-magnetic saturation of the CT's plus the connection of antiparallel thyristor reduces significantly the energy dissipated in the varistor during the power system fault, thus increasing the reliability of the proposed protection scheme at a small cost. The use of a CT with high-saturation point increases the amount of energy dissipates in the varistor. By using a CT with low-saturation characteristics the energy dissipated in the varistor is significantly reduced, as it is illustrated in Fig. 9, although the secondary current waveform is more distorted.

IV. EXPERIMENTAL RESULTS

In order to validate the protection scheme proposed in this paper, a 5-kVA prototype was implemented and tested for different protection configurations. The experimental primary and secondary currents of the CT connected to a small resistance are shown in Fig. 14. These figures illustrate how the magnetic saturation of the CT reduces the secondary current amplitude and distort the current waveform.

Fig. 15 shows the current waveform of the protection scheme implemented only with the varistor. Finally, Fig. 16 shows the current waveform for the protection scheme implemented with the varistor and the antiparallel thyristors. In this case, the current flowing through the varistor is reduced

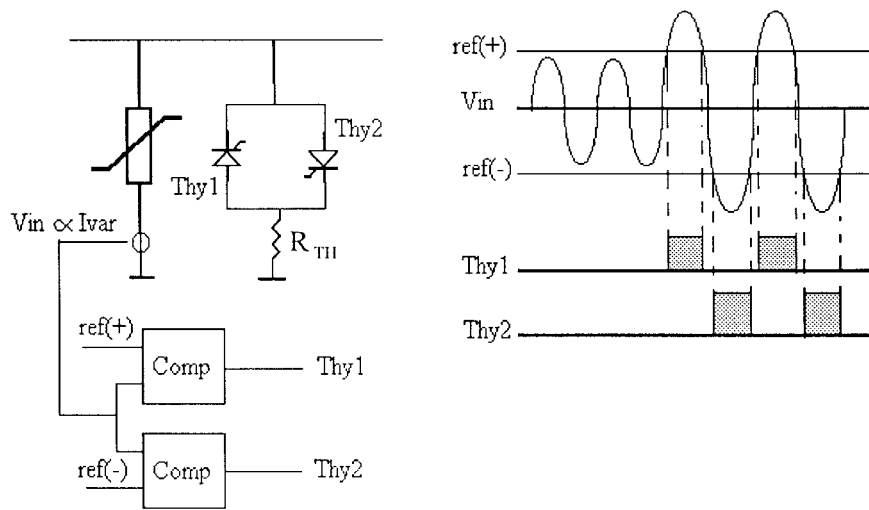

Fig. 13. The control circuit that generates the gating signals to the thyristors.

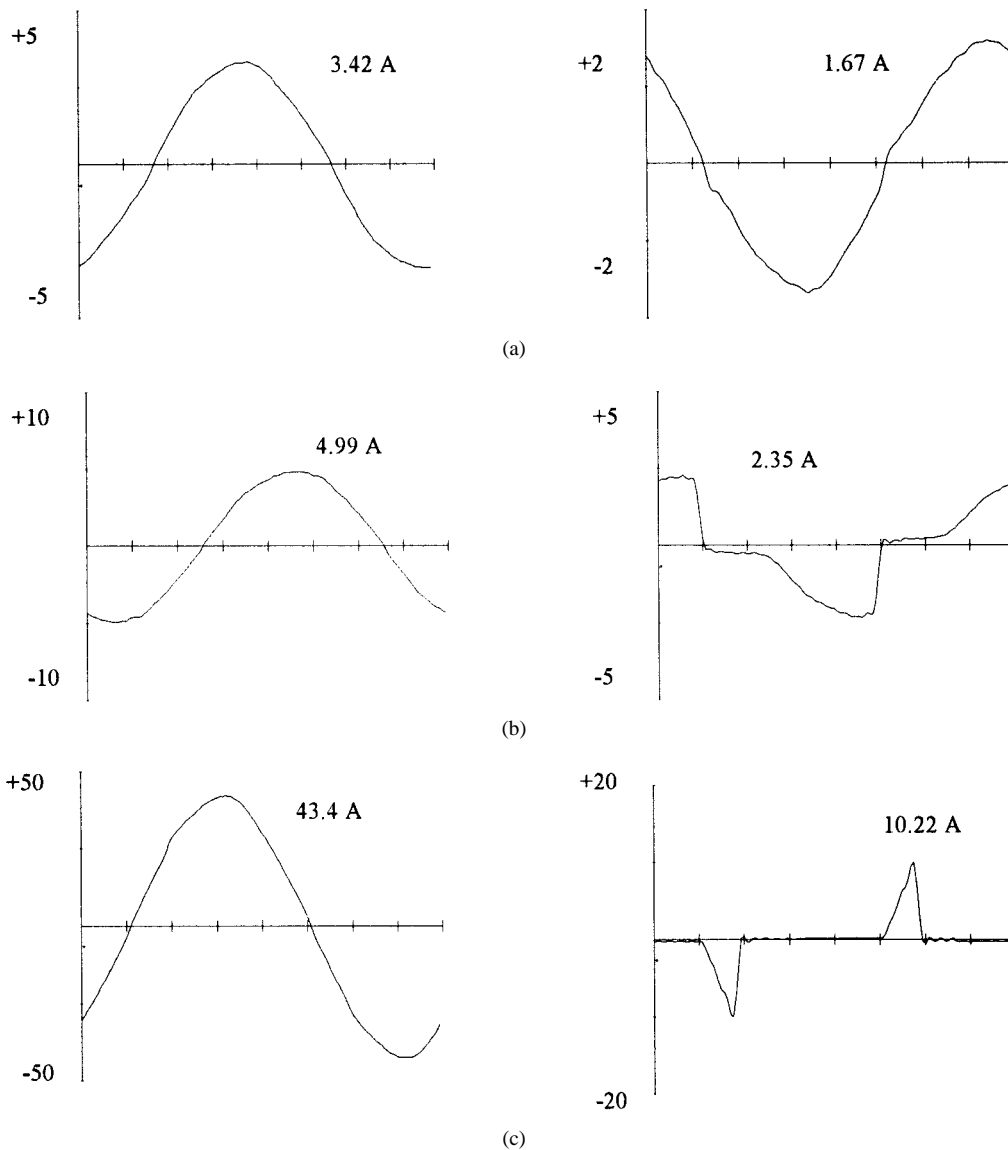

Fig. 14. Experimental transformer current waveforms for different values of primary currents: (a) primary and secondary currents for linear region, (b) primary and secondary currents for low-magnetic saturation, and (c) primary and secondary currents for high-magnetic saturation.

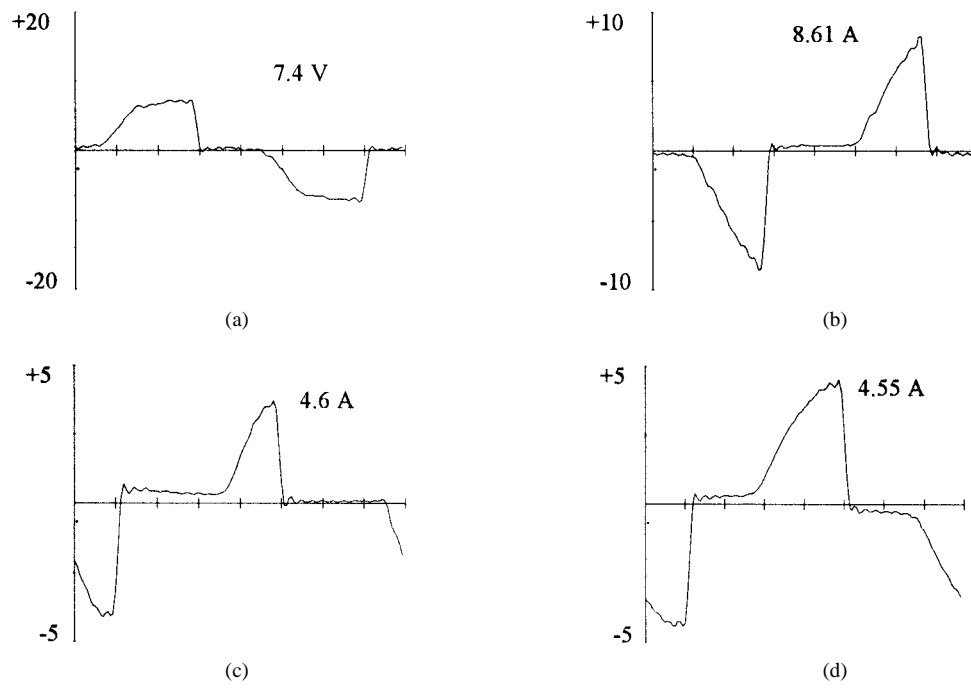

Fig. 15. Experimental waveforms for the protection scheme implemented only with the varistor: (a) CT secondary voltage, (b) CT secondary current, (c) varistor current, and (d) inverter ac current.

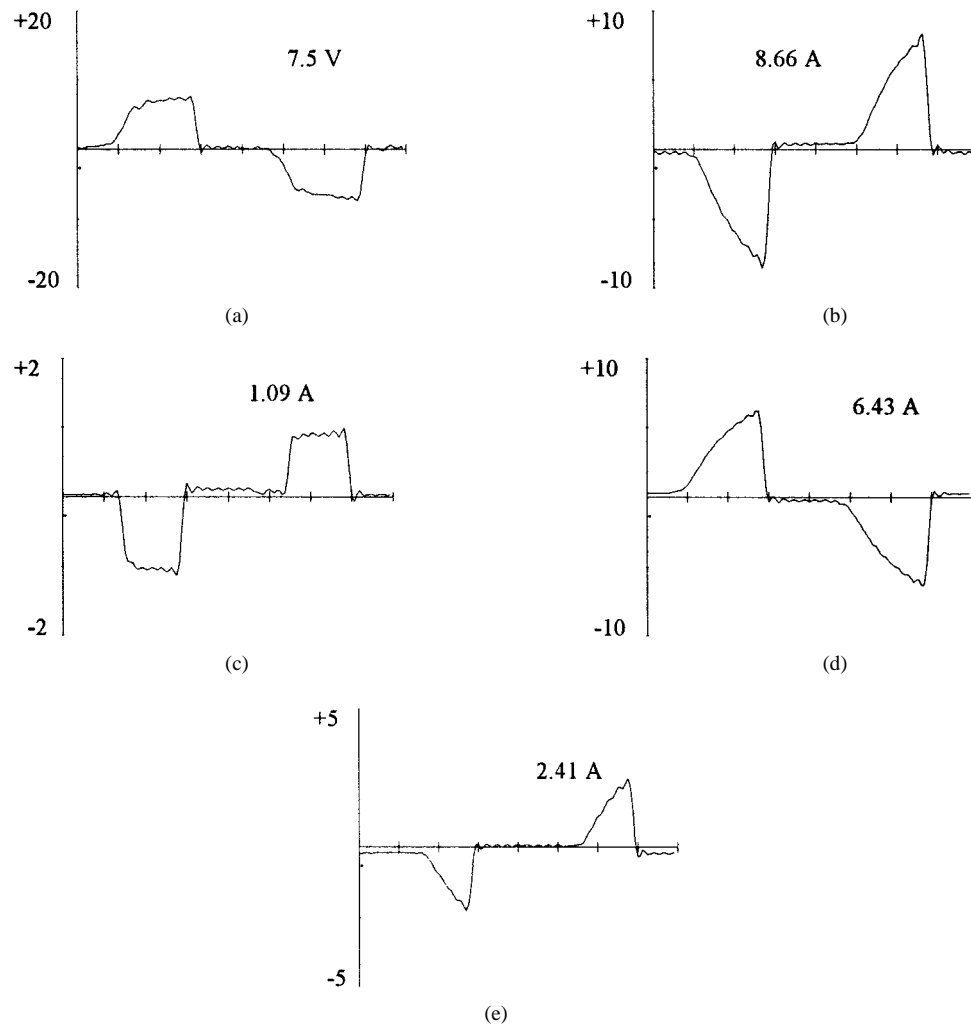

Fig. 16. Experimental current waveforms for the protection scheme implemented with the varistor and thyristors: (a) CT secondary voltage, (b) CT secondary current, (c) varistor current, (d) current through the thyristors, and (e) inverter ac current.

from 4.6 A peak to 1.09 A. Also, the inverter ac current is reduced from 4.55 to 2.41 A.

V. CONCLUSIONS

A protection scheme for series active power filters has been presented and analyzed in this paper. The proposed scheme protects series active power filter when short-circuit faults occur in the power distribution system. The principal protection element is a varistor. The combination of low-saturation magnetic characteristic of the current transformers with the use of antiparallel thyristors helps to reduce the power dissipated by the varistor. The technical viability of the proposed scheme was proved by simulation using PSPICE and with an experimental setup of 5 kVA.

ACKNOWLEDGMENT

The authors would like to thank R. Oyarzun for the technical assistance given during the development of this paper.

REFERENCES

- [1] W. M. Orady, M. L. Samotyj, and A. H. Noyola, "Survey of active power line conditioning methodologies," *IEEE Trans. Power Delivery*, vol. 5, pp. 1536–1542, July 1990.
- [2] H. Akagi, "Trends in active power line conditioners," in *Conf. Proc. IECON' 92*, pp. 19–24.
- [3] F. Z. Peng, H. Akagi, and A. Nabae, "A new approach to harmonic compensation in power systems," in *Proc. IEEE/IAS Annu. Meeting*, 1988, pp. 874–880.
- [4] ———, "Compensation characteristics of the combined system of shunt passive and series active filters," *IEEE Trans. Ind. Applicat.*, vol. 29, pp. 144–151, Jan./Feb. 1993.
- [5] A. Campos, G. Joos, P. Ziogas, and J. Lindsay, "Analysis and design of a series voltage unbalance compensator based on a three-phase VSI operating with unbalanced switching functions," in *Proc. IEEE/PESC*, 1992, pp. 1221–1228.
- [6] F. Z. Peng, H. Akagi, and A. Nabae, "A new approach to harmonic compensation in power systems—A combined system of shunt passive and series active power filters," *IEEE Trans. Ind. Applicat.*, vol. 26, pp. 983–990, Nov./Dec. 1990.
- [7] Power Engineering Committee of the IEEE-IAS, *Recommended Practice for Electric Power Distribution for Industrial Plants*. New York: Wiley Interscience, 1986.
- [8] *Transient Voltage Suppression*, 3rd ed., General Electric Company, 1992.



Luis A. Morán (S'79–M'81–SM'94) was born in Concepción, Chile. He received the degree in electrical engineering from the University of Concepción, Concepción, Chile, in 1982, and the Ph.D. degree from Concordia University, Montreal, P.Q., Canada, in 1990.

Since 1990, he has been with the Electrical Engineering Department, University of Concepción, where he is an Associate Professor. He is also a Consultant for several industrial projects. His main areas of interest are static var compensators, active power filters, ac drives, and power distribution systems.



Ivar Pastorini was born in Concepcion, Chile. He completed undergraduate studies in electrical engineering at the University of Concepcion, Concepcion, in 1997.

His interests include reactive power compensation, active power filters, and power distribution systems.

Juan Dixon (M'90–SM'95) was born in Santiago, Chile. He received the degree in electrical engineering from the University of Chile, Santiago, in 1977 and the M.Eng. and Ph.D. degrees in electrical engineering from McGill University, Montreal, P.Q., Canada, in 1986 and 1988, respectively.

Since 1979, he has been with the Pontificia Universidad Católica de Chile, Santiago, where he is an Associate Professor in the Department of Electrical Engineering in the areas of power electronics and electrical machines. His research interests include electric traction, machine drives, frequency changers, high-power rectifiers, static var compensators, and active power filters.

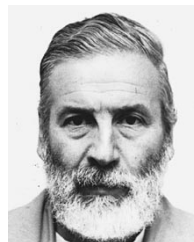

Rogel Wallace (A'86) received the degree in electrical engineering from the Universidad Técnica Santa María, Valparaíso, Chile, in 1966 and the Ph.D. degree in electrical engineering from the Moscow Power Institute, Moscow, U.S.S.R., in 1976.

He was a Post-Doctoral Fellow in electrical machine design at the Moscow Power Institute. Since 1980, he has been with the Department of Electrical Engineering, University of Concepción, Concepción, Chile, where he is currently a Professor. His teaching and interests include electrical machine design, power electronics, variable-frequency drives, and control system theory applied to electrical drives.