

A SIMPLIFIED CONTROL SYSTEM FOR SERIES CONNECTED, AC-DC PWM CONVERTERS, FOR BACK-TO-BACK MULTITERMINAL SYSTEMS

Juan W. Dixon, Diego R. Veas
 Dept. of Electrical Engineering
 Universidad Católica de Chile
 Casilla 306, Correo 22
 Santiago, Chile
 FAX +56-2-552-2563

Boon T. Ooi
 Dept. of Electrical Engineering
 McGill University
 2480 University St.
 Montreal P. Q. H3A-2A7, Canada

Abstract. - Voltage source, PWM rectifiers are able to work with near sinusoidal current waveforms and unity or even leading power factor. From the point of view of the dc link, these rectifiers reverse power through current instead of voltage reversal, allowing to have back-to-back multiterminal converter topologies. However, some problems related with this system, are the complexity of the control circuit, the stability of the system and the dc voltage-sharing between converters. This paper analyzes these problems and proposes a simple solution, based on the detection of the dc current instead of the dc voltage, using an unique predefined PWM pattern, stored in an EPROM, for each converter. The patterns are phase shifted following the load current variations, allowing to control the voltage of the dc link. The main characteristics of this solution are a) there is no Master rectifier (all are hierarquically identical); b) the stability does not depends on the size of dc capacitors, c) it can work at leading power factor for all load conditions and d) it can be adjusted to work at zero regulation. Computer simulations, mathematical analyses and some experimental results with a 2-kw voltage regulated PWM prototype are included in the paper.

I. INTRODUCTION

Conventional back-to-back thyristor HVDC systems are known to have a lot of drawbacks, such as high harmonic distortion, poor power factor, and power reversal through voltage reversal instead of current reversal. Harmonic distortion have to be reduced with the help of passive filters and special connection transformers. The poor power factor becomes worst when converters operate with large delay firing angles. The power reversal through voltage reversal does not permit multiterminal connections or at least make it difficult to implement. By using voltage source PWM rectifiers, the power reversal through current reversal becomes possible [1]. Besides, power factor can be controlled to be leading or unity and the current almost sinusoidal [2,3]. If they are connected in series or in parallel, it becomes possible to have very good quality currents for high power rectifiers, by using each individual PWM with their carriers shifted [4]. However, as these rectifiers work through a dc voltage capacitor feedback control loop, to drive such a system from the control point of view results difficult, due to stability problems [5-7]. This paper presents a different approach to control a series connection system like this, by controlling the current instead of the voltage in the dc link [8].

The Figure 1 shows the schematic of a PWM-HVDC N-terminal system in wich one terminal, called "Main Terminal", controls the dc voltage and the other N-1 terminals, called

"Distributer Terminals", control the power injection, which can be either positive or negative. All the terminals can operate at unity or even leading power factor for all load conditions. More "Distributer" terminals can be directly connected to the dc link, providing that the total amount of power coming from the "Main" terminal do not exceed the ratings of this terminal. The problem with this kind of system is to ensure adequate stability and voltage sharing between the converters at each terminal.

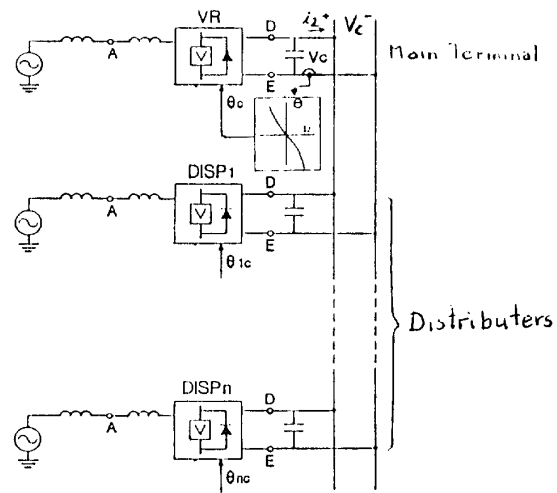

Fig. 1. HVDC Back-to-Back Multiterminal System

The Fig. 2 shows the squematic of the "dc current controlled rectifier", whose operational stability characteristics have already been discussed in [8]. This rectifier can work as a rectifier as well as an inverter, allowing the implementation of multiterminal Back-to-Back systems. To be able to use this kind of rectifier in a Back-to-Back HVDC system, many of these converter modules have to be connected in series to form the "Main" and all the "Distributer" terminals to be required. The control scheme for the "Main" terminal consists on measuring the dc link current, i_d , and through it shift the power angle θ of all the rectifiers in this terminal. Each rectifier has it proper PWM information stored in an EPROM, which is unique and contains the information of the fundamental voltage generated by each converter. All the fundamentals of each PWM are the same but the harmonics in each one are shifted in such a form that the more important of them are canceled [4,6]. The "Distributer" terminals are connected to the dc voltage

generated for the main terminal and the power injection, which can be either positive or negative, is controlled through the θ angle of each distributor in an independent form. The θ angle which controls the power injection of the "Distributors" is called $\theta_{CONTROL}$. The voltage sharing between the converters of the "Distributors" is automatically equalized due to the fact that all the rectifiers are identical and are operated with the same $\theta_{CONTROL}$. This Control scheme has the following advantages with respect to the systems proposed in [5]: a) the stability becomes very strong because it does not depend on the size of the dc capacitors [8]; b) the "Master Rectifier" [5] disappears, and then all the converters in the chain, have the same hierarchy and c) It is required just one current sensor to control the overall system. The Fig. 2 shows the schematic of a "dc load current controlled rectifier" and Fig. 3 the proposed "back-to-back system" for a two-terminal configuration. As it was already mentioned, the series connection of each terminal also permits the elimination of unwanted harmonics by suitably shifting the triangular carriers of each one of the N rectifiers in the bridges.

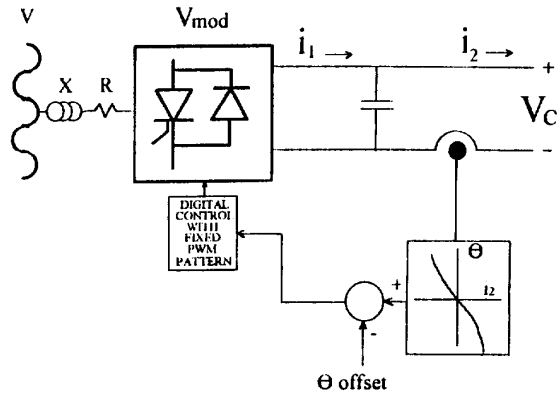

Fig. 2. Schematic of a "dc load current controlled rectifier"

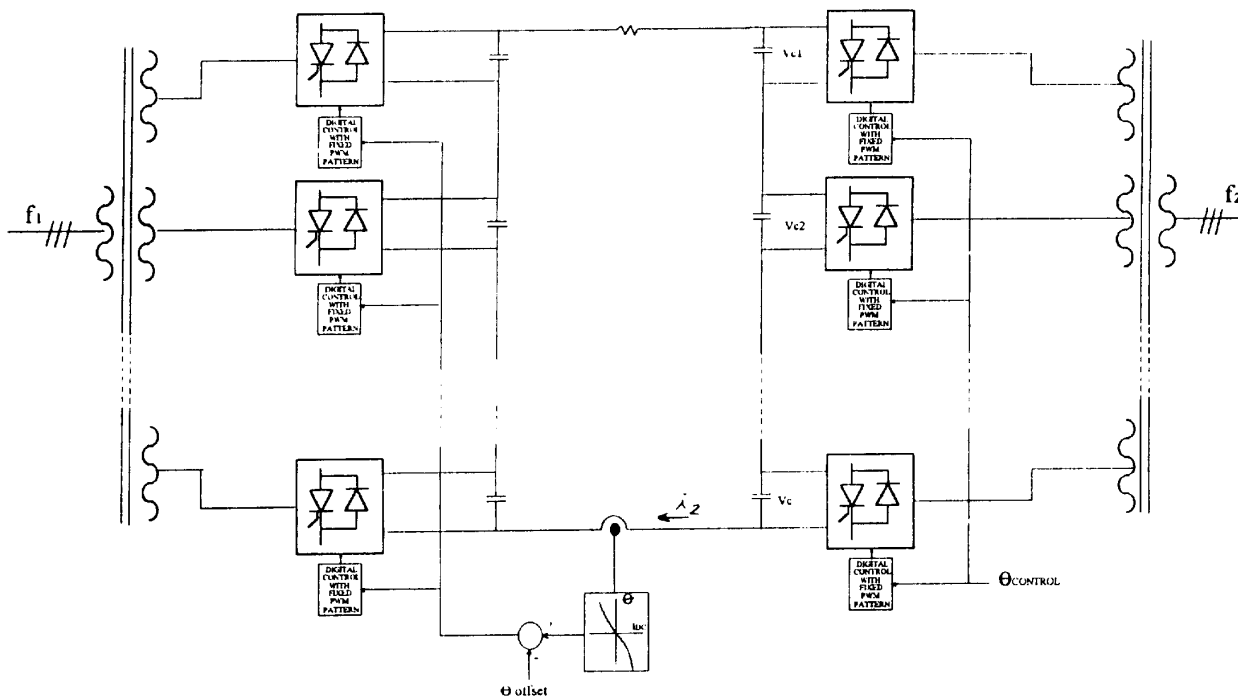

Fig. 3. "Back-to-back system" for a two-terminal configuration

II. PRINCIPLE OF OPERATION

The "dc load current controlled rectifier" shown in Fig. 2, whose operation principle is used to control the "Main" terminal in the back-to-back system is as follows: the voltage V_{MOD} , shown in the phasor diagram of Fig. 4, modulated by the rectifier, is produced by a unique PWM pattern, which is shifted with respect to the mains voltage V , to change the power angle θ and hence the amount of power flow transferred from the ac to the dc side.

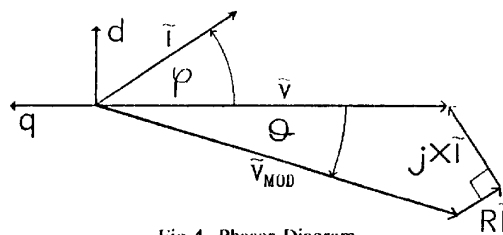

Fig. 4. Phasor Diagram

When the power angle is negative (V_{mod} lags V), the power flow goes from the ac to the dc side. When the power angle is positive, then the power flows in the opposite direction. The dc load current allows to control this power angle θ establishing a stable dc voltage operation for each dc current and power angle. With this characteristic, it is possible to find a relation between the dc current and the input power angle, to have zero dc voltage regulation for all load conditions. Then, without the need of measuring the dc voltage and with only one PWM pattern, the dc voltage can be kept constant. This situation may include both rectifier operation and inverter operation. Now, when many converters are connected in series, the PWM patterns of each converter, which are stored in EPROM's, can be designed to produce harmonic cancelation, making it possible to have very good quality sinusoidal currents, even with slow commutation devices such as high power GTO's.

The first problem, related with stability and voltage sharing of the converters connected in series of Fig. 3, is explained with the help of Fig. 5. When the rectifier is under steady-state, the power angle θ , who comes from the θ - i_d feedback loop, is constant and hence, any perturbation at the dc link voltage only affects the amplitude of V_{mod} , making the input currents to move following the "ac locus", shown in Fig. 5, to satisfy the phasor diagram. But, because of the power balance between the ac and the dc side of the converter, the load current i_d tries to force the input current I to follow the "dc locus", also shown in the same figure. The intersection of these two loci represents a stable equilibrium point, because when the dc voltage increases (decreases), less (more) power comes from the ac side, discharging (charging) the dc link capacitor. This situation forces the voltage to return to the equilibrium point. Similar reasoning can be used for the inverter mode of operation, in which a stable equilibrium point is also reached. It can be seen from Fig. 5 that the equilibrium point is stable and only possible when $R > 0$. In practical converters R is always positive and hence the system cannot be unstable. The same reasoning is valid when N converters are connected in series to implement the "Main" and the "Distributer" terminals, as in Fig. 3. Such a system also becomes stable for both rectifier and inverter operation. However, the stability can also be explained in mathematical form.

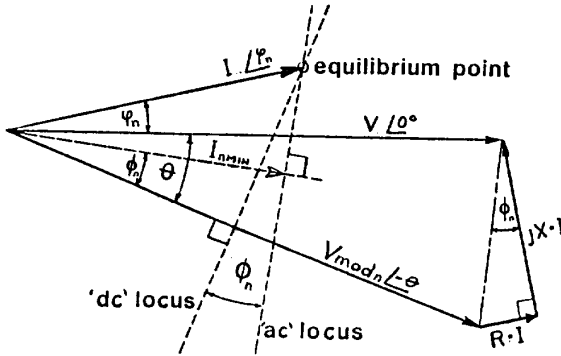

Fig. 5. Phasor diagram to show stability principle

III. STABILITY

The stability of the "Main" terminal is evaluated assuming that the frequency of the PWM pattern of each converter is high enough, to neglect the harmonics. Analyzing the system through the d-q frame, the following equations for the jth converter in the "Main" terminal chain, can be written:

$$(L \cdot di_a/dt + R \cdot i_a - X \cdot i_q) = (v_a - v_{mod_a}), \quad (1)$$

$$(L \cdot di_q/dt + X \cdot i_a + R \cdot i_q) = (v_q - v_{mod_q}), \quad (2)$$

where

$$(v_{mod_a})_j = -\sqrt{3}(|V_{mod}| \sin \theta), \quad (3)$$

and

$$(v_{mod_q})_j = -\sqrt{3}(|V_{mod}| \cos \theta), \quad (4)$$

These two differential equations, (1) and (2), represent the ac side of the jth rectifier. The differential equation for the dc side of this converter is:

$$(C \cdot dv_o/dt)_j = (i_1)_j - i_2 \quad (5)$$

$(i_1)_j$ represents the output rectifier dc current of the jth converter and i_2 , the dc link current which is common to all the rectifiers in the chain and represents the forcing function. Input and output equations are related through the power balance equation of the dc and the ac sides. According with [8], i_1 can be evaluated in terms of i_d and i_q in the jth converter:

$$(i_1)_j = -\sqrt{3} \cdot K_v (i_d \cdot \sin \theta + i_q \cdot \cos \theta), \quad (6)$$

where k_v represents the relation between V_{mod} and V_c , which is constant (PWM unique) and the same for all the converters

$$|V_{mod}|_j = k_v \cdot V_c, \quad (7)$$

The θ angle is common to all the converters in the chain ($\theta_j = \theta_i = \theta$) and depends on the forcing function i_2 . Then, it can be considered constant for the analysis. Replacing (3), (4), (6) and (7) into (1) and (2):

$$(L \cdot di_a/dt)_j = (-R \cdot i_a + w \cdot L \cdot i_q - K_d \cdot v_o), \quad (8)$$

$$(L \cdot di_q/dt)_j = (-w \cdot L \cdot i_a - R \cdot i_q - K_q \cdot v_o - \sqrt{3}V), \quad (9)$$

where

$$K_d = -\sqrt{3} \cdot K_v \cdot \sin \theta \quad (10)$$

and

$$K_q = -\sqrt{3} \cdot K_v \cdot \cos \theta \quad (11)$$

There are three unknown values in (8) and (9): i_a , i_q , and v_o . The third equation is obtained by replacing (6), (10) and (11) into (5):

$$(C \cdot dv_o/dt)_j = K_d \cdot (i_a)_j + K_q \cdot (i_q)_j - i_2 \quad (12)$$

Equations (8), (9) and (12) can be written in the form:

$$\dot{x} = [A] \cdot x + B \quad (13)$$

where

$$[A] = \begin{bmatrix} -R/L & w & -K_d/L \\ -w & -R/L & -K_q/L \\ K_d/C & K_q/C & 0 \end{bmatrix} \quad (14)$$

The stability of each converter can be found through the eigenvalues of the $[A]$ -matrix:

$$\det(S[I] - [A]) = 0 \quad (15)$$

or:

$$a_0 s^3 + a_1 s^2 + a_2 s + a_3 = 0 \quad (16)$$

Applying the Routh's Criterion ($a_j > 0$ for $j=0,1,2,3$ and $a_1 a_2 - a_0 a_3 > 0$) it is found that each converter is stable if and only if $R > 0$ and $L > 0$. These two conditions are automatically satisfied, because L is necessary for commutation and R is always positive.

The analysis also shows, unlike other control methods, that the stability is independent of the size of the dc capacitor.

For the "Distributor" terminals the dc voltage V_c is imposed by the M converters in series of the "Main" terminal.

IV. VOLTAGE SHARING

According with [8], The dc voltage of each converter in one terminal of the back-to-back system, depends on the power angle Θ and the dc current i_2 .

$$V_c = V_{co} \cdot [\cos\theta - (X/R)\sin\theta - i_2 \cdot (R^2 + X^2) / (3 \cdot V \cdot K_v \cdot R)] \quad (17)$$

where X , R and V are the input reactance, resistance and voltage respectively. Eq. (17) can be generalized adding the subscript j , and considering that V , i_2 and Θ are common to all the rectifiers in one terminal

$$V_{c_j} = V_{co} \cdot [\cos\theta - (X/R)_j \sin\theta - i_2 \cdot (R^2 + X^2)_j / (3 \cdot V \cdot K_v \cdot R_j)] \quad (18)$$

In the "Main" terminal, the power angle Θ and i_2 are related through the dc current controlled feedback, which imposes a particular value of Θ for each dc load current i_2 . In particular, to get zero regulation operation [8], the following relation between Θ and i_2 have to be implemented:

$$\cos\theta - (X/R)\sin\theta - 1 = i_2 \cdot (R^2 + X^2) / (3V \cdot K_v \cdot R) \quad (19)$$

In the chain of converters, Θ , i_2 , V , and K_v are the same and then the difference in the dc voltage between each converter will depend on R and X . Eq.(19) will ensure zero regulation in the converter whose values of X and R correspond exactly with the values assigned in (19), which will be called the "reference converter". The rest will have differences which can be evaluated through:

$$\Delta V_c = V_c - V_{c_j} \quad (20)$$

where V_c is the voltage of the reference converter, from which (19) has been defined and V_{c_j} , the dc voltage in the j th converter. Replacing (17) and (18) into (20) it yields:

$$\Delta V_c = V_{co} \left[\left(\frac{X_j}{R_j} - \frac{X}{R} \right) \sin\theta - \frac{i_2}{3V K_v} \left(\frac{R^2 + X^2}{R} - \frac{R_j^2 + X_j^2}{R_j} \right) \right] \quad (21)$$

Eq.(21) allows to evaluate the displacement of V_{c_j} (in the j th converter) with respect to the reference converter.

In the "Distributor" terminals, the dc voltage is imposed by the "Main" terminal and is approximately equal to $M V_c$, where M is the number of converters in the "Main". This voltage is shared between the N converters of the particular "Distributor" as shown in Fig.6.

In the "Distributor" terminals Θ becomes $\Theta_{CONTROL}$, and is the same for each converter. The current i_2 is also common and the output ac voltage is the same. Hence, the dc voltage sharing will again depend on X_j and R_j of the "Distributor". The difference is that the N converters are forced to accept the dc voltage generated for the "Main" terminal, which is $M V_c$.

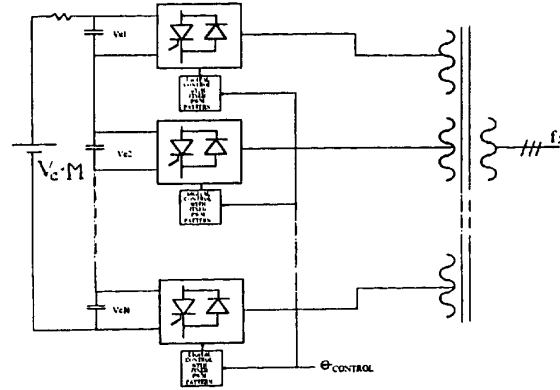

Fig.6. "Distributor" terminal

V. POWER FACTOR ADJUSTMENT

One of the features of these converters is that they can work at leading power factor for all load conditions. In the case of the "Main" converter, their rectifiers work using the principle of Θ_{OFFSET} , discussed in [8], which permits to adjust the power angle through the addition of Θ_{OFFSET} in the dc current feedback loop as shown in Fig. 2. Then Θ_{OFFSET} , is adjusted to have leading power factor for both, rectifier and inverter operation.

The "Distributor" terminals are not power factor adjustable. However, the power factor can be made leading by the proper adjustment of the magnitudes of V_{MOD} and V , before the converter implementation, as shown in Fig. 7.

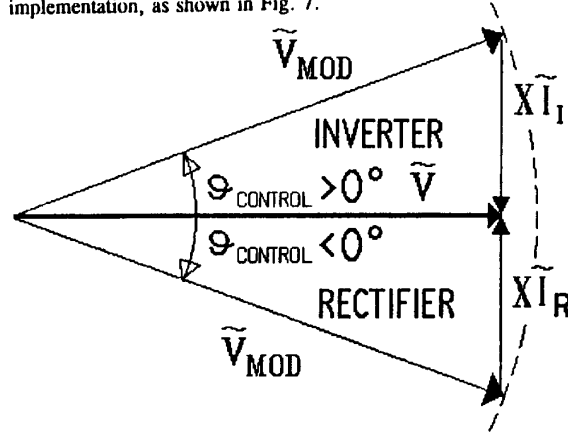

Fig.7. "Distributors" Phasor diagram for leading power factor

In this figure, the relative magnitudes of V and V_{MOD} are selected according with the maximum values that $\Theta_{CONTROL}$ can take, either positive or negative. Under these conditions, the leading power factor is ensured within the normal operating region of the terminal. The magnitude of V is given by the ac transformer, who links the mains with the the converter, and hence can be choiced before the implementation of the system. V has to be slightly smaller than V_{MOD} . The magnitude of V_{MOD} is constant because it depends on V_c and the PWM pattern, but can be modified by changing this pattern, through the replacement of the ROM memories where the PWM information is stored. This will allow to increase or decrease the value of V_{MOD} .

VI. SIMULATIONS AND EXPERIMENTAL RESULTS

The dc voltage sharing between the converters is one of the problems related with the series connection. To know that, the eq.(21) can be used, considering different X/R ratios of the "Main" converter and adjusting one of the converters to have zero regulation operation. The Figs. 8 and 9 show graphically the effect of the X_i variations on ΔV_c , for X/R=5 and X/R=10 respectively.

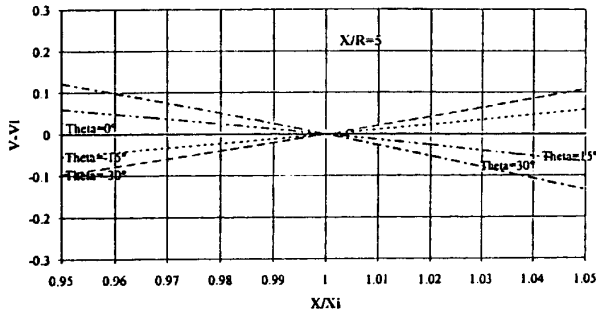

Fig. 8. Parameter sensitivity to X_i variations for X/R=5

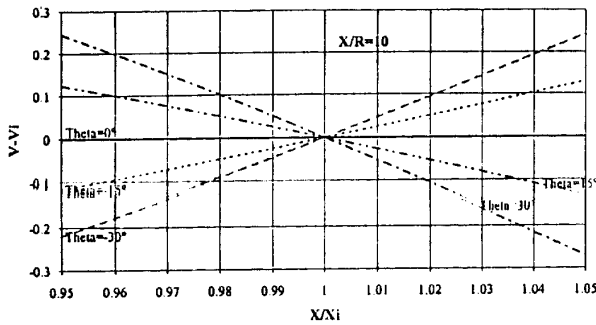

Fig. 9. Parameter sensitivity to X_i variations for X/R=10

It can be noted that the X/R ratio has an important influence in the ΔV_c variation. The bigger is this ratio, the more sensitive becomes the system. In the case of X/R=10, the deviations of X_i should not be bigger than 2% of the reactance of the "reference" converter. These narrow tolerances can be reached using a common core, multi-secondary winding transformer.

The Fig. 10 shows the effect of R_i variations for X/R=10. It can be noted that it produce a negligible effect on ΔV_c compared with X_i .

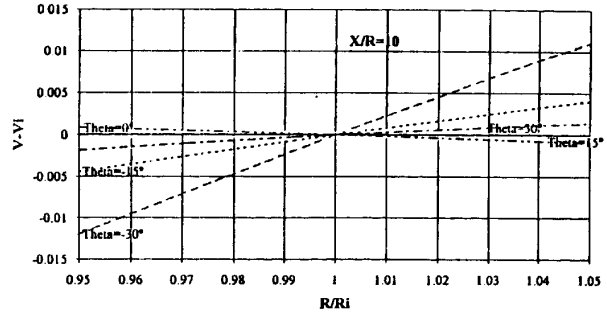

Fig. 10. Parameter sensitivity to R_i variations for X/R=10.

The Fig. 11 shows a simulation for a back-to-back two terminal system, in which the "Main" and the "Distributor" rectifier are formed by three identical converters each. The "Main" side is connected to a 50 Hz system and the "Distributor" to a 60 Hz system. The total power of each terminal is S=2 MVA. The total dc voltage has been settled in 7,200 volts. The switching frequency of the "Main" is 750 Hz for each converter. For the "Distributor" converter, the switching frequency is 900 Hz. In both the cases, the switching times have been shifted between converters to eliminate harmonics. It can be noted that the currents in both sides are almost sinusoidal. The simulation starts at no-load condition, following with a power flow from the "Main" to the "Distributor" and then from the "Distributor" to the "Main". To do that, the angle $\Theta_{CONTROL}$ is changed from zero to +25° and then to -25°. The block of power changes from zero to +2 MW to -2MW. In the upper line of Fig. 11, the ac voltage V_M and current I_M for one phase in the "Main" converter is shown. The middle line shows the dc current (which changes from zero to 300 to -300 amps. approximately), the dc voltage drop and the $\Theta_{CONTROL}$ steps. Finally, the lower line, shows the ac voltage V_D and current I_D for one phase in the "Distributor" converter. The voltage is 1 kV rms for each converter in both "Main" and "Distributor" terminal.

It can be observed that the system has a good dynamic response, reaching equilibrium, after a change in $\Theta_{CONTROL}$, in a couple of cycles at the ac sides and in around six cycles at the dc link. The simulation also shows the good power factor operation which is lightly leading, in both the terminals.

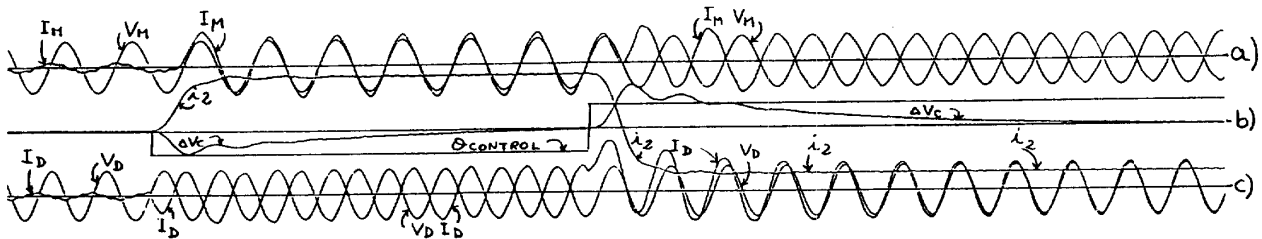

Fig. 11. Power reversal simulation for X/R=5
a) "Main" terminal voltage (V_M) and current (I_M)
b) dc link current (i_1) and error voltage (ΔV_c)
c) "Distributor" voltage (V_D) and current (I_D)

Economical reasons have not permitted to implement a complete back-to-back system. However, some experiments have been carried out using two converters identical to emulate the "Main" converter. The Fig. 12 shows experimentally a step response for two 2-kW series-connected rectifiers. The load dc current i_L changes from 0 to 6 A dc. The dc voltages, and the phase currents are displayed. The dc voltage $V_{co}=120$ V. The system is using the same θ angle for both converters and it can be seen that the dc voltages follow the same transient variations.

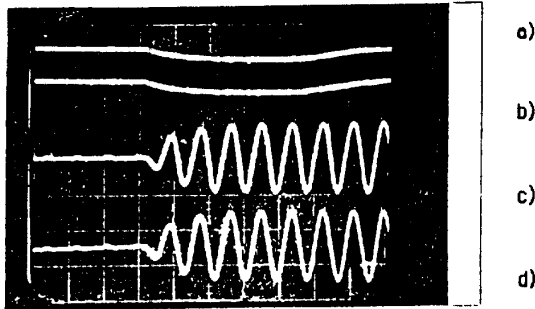

Fig.12. Experimental oscillogram for a step response
a) voltage V_{c1} b) voltage V_{c2}
c) ac current I_1 d) ac current I_2

VII. CONCLUSION

A simple control system configuration for back-to-back multiterminal system has been presented. It comprises a "Main" terminal, who keeps the dc voltage at zero regulation, using a feedback loop to change the power angle θ through the dc link current. The direction and amount of power flow is controlled through $\theta_{control}$, in the "Distributor" terminals. Analytical equations have been developed for stability and have been verified experimentally and by computer simulations. From these equations, the following conclusions can be made:

- 1) The only condition for stability is that $R_i > 0$ for all the j th converters. This condition is always satisfied because in real systems R_i neither can be zero nor negative.
- 2) The equations permit one to predict the parameter sensitivity of the system under variations in the input values of impedances of each converter with respect to the "reference" converter.
- 3) The power factor of all terminals can be adjusted to work at leading power factor operation for all load conditions.
- 4) They can be used to predict the behaviour of small or very large rectifiers. They represent a useful tool for the design of this type of system.

The weak point of this configuration is that the voltage sharing is very sensitive to reactance variations. To reduce this problem, it is recommended to use a common core multi-secondary transformer in each terminal. In this form, the reactances can be made very similar, allowing a good voltage sharing between converters.

REFERENCES

- [1] J. A. Wilson, "The forced Commutated Inverter as a Regenerative Rectifier", IEEE Trans. on Ind. Appl., Vol. IA-14 No.4, July/Aug. 1978, pp 335-340.
- [2] J. W. Dixon, A. B. Kulkarni, M. Nishimoto and B. T. Ooi, "Characteristics of a Controlled-Current PWM Rectifier-Inverter Link", IEEE Trans on Ind. Appl., Vol. IA-23 N°6, Nov./Dec. 1987, pp. 1022-1028.
- [3] J. W. Dixon and B. T. Ooi, "Indirect Current Control of a Unity Power Factor Sinusoidal Current Boost Type Three-Phase Rectifier", IEEE Trans. on Ind. Electronics, Vol. IE-35 N°4, Nov. 1988, pp. 508-515.
- [4] J. Holtz, W. Lotzkat and K. H. Werner, "A High-Power Multi Transistor-Inverter Uninterruptible Power Supply System", IEEE Pesc'86 Record, 1986, pp 311-320.
- [5] J. W. Dixon and B. T. Ooi, "Series and Parallel Operation of Hysteresis Current-Controlled PWM Rectifiers", IEEE-IAS Annual Meeting, Oct. 1987, pp 641-647.
- [6] B. T. Ooi, Y. Guo, X. Wang, H. C. Lee, H. L. Nakra and J. W. Dixon, "Stability of PWM HVDC Voltage Regulator Based on Proportional-Integral Feedback", 4th European Conference on Power Electronics, EPE'91, Florence, Italy, 1991.
- [7] J. W. Dixon and B. T. Ooi, "Dynamically Stabilized Current Controlled SPWM Boost Type Three-Phase Rectifier", IEEE-IAS Annual Meeting, October 1988.
- [8] D. R. Veas, J. W. Dixon and B. T. Ooi, "A Novel Load Current Control Method for a Leading Power Factor Voltage Source PWM Rectifier", IEEE Trans. on Power Electronics, March 1994.
- [9] M. Brechbuhler and B. Skrabo, "The Static Converter as Modern Power Controller", Brown Boveri Rev., Vol. 69 No.12, Dec. 1982, pp 441-452.
- [10] L. Malesani and P. Tenti, "Three-Phase AC/DC PWM Converter with Sinusoidal AC Currents and Minimum Filter Requirements", IEEE Trans on Ind. Appl., Vol. IA-23 No.1, Jan/Feb 1987, pp 71-77.
- [11] S. K. Biswas, M. S. Mahesh and B. S. Ramakrishna, "A Three-Phase GTO AC to DC Converter with Input Displacement Factor and Output Voltage Control", IEEE-IAS Annual Meeting, Oct.1987, pp 684-690.
- [12] B. T. Ooi, J. C. Salmon, J. W. Dixon and A. B. Kulkarni, "A three-Phase Controlled Current PWM Converter With Leading Power Factor", IEEE Trans. on Ind. Appl. Vol. IA-23 No.1, Jan/Feb 1987, pp 78-84.
- [13] H. S. Patel and R. F. Hofi, "Generalised Techniques of Harmonic Elimination", IEEE Trans. on Ind. Appl., Vol. IA-9 No.3, 1973, pp 310-313.
- [14] Xiaoliang Ma, "High-Performance PWM Frequency Changers", IEEE Trans. on Ind. Appl., Vol. IA-22 No.2, March/April 1986, pp 267-280.